

**Byeongmin Kim** 2026  
Portfolio





# Byeongmin Kim

Industrial Designer

Phone : +82) 01029028983  
Email : kbm89791@gmail.com

## Education

**College for Creative Studies** in Transportation Design

FALL 2022, Detroit, MI

Bachelor of Fine Arts, graduated in May, 2025

**Pukyong National University** in Industrial Design

2019, Busan, Korea

**Kyungsung University** in Economics and Logistics

2017 - 2018 Busan, Korea

## Projects

**GM Dream Racer**

2025, Detroit, MI

This is GM Sponsor Studio's 2040 performance car project. It is a next-generation racing concept designed for a future race track equipped with wireless charging and a rail system. The car allows drivers to experience both GT mode and MIDSHIP mode simultaneously, and enhances the driving excitement with a virtual booster effect.

**Nissan Zen-Mobility**

2025, Detroit, MI

This is a two-week mobility design study, envisioned for the year 2040 in the dense urban context of Tokyo. It explores an autonomous ride-sharing system designed to alleviate the stress caused by crowded public transportation and polluted air, while ensuring accessibility for busy workers and vulnerable groups such as pregnant women, the elderly.

**Jeep Huntington**

2024, Detroit, MI

This project is designed for younger couples who want to enjoy sunbathing and surfing anytime, without the need for preparation. The vehicle features a flexible roof system with rails—it functions as a roof while driving and transforms into a comfortable sunbed at the beach. It also includes a lightweight surfboard that doubles as a door in driving mode. This Jeep is always ready for an adventure under the sun, whenever you are.

**Alfa romeo Hydrogenic**

2024, Detroit, MI

This is the 2040 Alfa Romeo three-seater performance vehicle powered by hydrogen and solar energy. It features a compact battery and an integrated solar panel, contributing to reduced weight and enhancing the exotic driving experience.

**Bentley Aurora**

2024, Detroit, MI

A 2045 electric boat project inspired by the aurora—an exclusive phenomenon limited by time and place. Its flowing, organic forms are expressed in both exterior and interior, enhancing a sense of refined luxury.

## Skills

**2D** (Visual Communication)

- Sketching / Marker Rendering / Adobe Photoshop / Adobe Illustrator / Adobe Premier

**3D** (Modeling)

- Autodesk Alias (Sub D) / Blender / Unreal / Clay Modeling

## Work Experience

- General Motors Design Sponsored Studio

2025, Detroit, MI

- American Chemistry Council Sponsored Clay modeling Studio

2024, Detroit, MI

- Republic of Korea Army Truck and Bus Driver & Car Maintenance Soldier

2015 - 2016, Gyeryong, Korea

## Language

- Korean / English / German

## Interests

-Listening Music / Traveling / Driving / Traveling / Communication

# Contents

01



Dream Racer

02



Huntington

03



Solaroid

04



Zen Mobility

05



Baobab

06



Aurora



 general motors

# Dream Racer

2040 Shared track racing car





## Dream Racer



Name : Lucas

Age : 34

Income : \$ 200.000 / Year

Location: San Jose, California, U.S

Wants :

Lucas is a software developer who spends most of his weekdays in the office. He is now trying to balance his work and personal life.

**Customer's Problem :** Lucas recently became interested in car racing and wants to experience it, but he's hesitant due to strict traffic laws, limited driving skills, and the high cost of vehicles and maintenance.



GM Racing Experience Center in 2040

## ■ Problem & Solution

**Solution :** In 2040, General Motors operates a **Racing Experience Center** that allows users like Lucas to enjoy car racing through a monthly subscription, without having to purchase expensive racing cars. By showcasing the company's advanced technology, GM promotes its brand and generates revenue through subscription fees and various additional services. AI-equipped racing cars enhance the exotic racing experience while minimizing the risk of accidents.

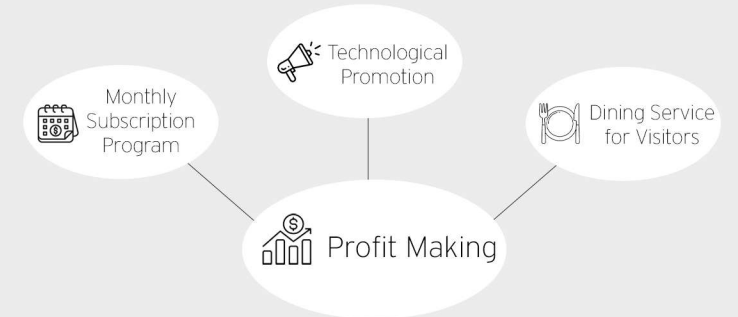



# Dream Racer

## Lucas's Journey Map



**1. Start Racing**  
It's his first time trying a car race, and since he's unfamiliar with the track.

**2. Support Driving**  
The AI-based UX/UI system supports and guides Lucas during his driving on the circuit.

**3. Wireless EV Charging**  
The wireless battery charging system frees the driver from manual charging and contributes to a lighter vehicle, enhancing the exotic driving experience.

**4. Entertainment**  
The UX/UI system provides entertainment features, such as 'competitor' and 'chaser' modes, making the racing experience on the circuit feel more like a video game.

**5. Driver Customized Setting**  
This car offers customizable settings, such as GT mode and Midship mode. The driver can select and adjust these settings based on personal preference.

**6. Maximize Exotic Racing**  
The booster effect provides explosive acceleration, maximizing the driver's exotic racing experience on the circuit.

**7. Finish Successful Racing**  
After enjoying his first race, Lucas is looking forward to his next exciting race.





Dream Racer

Dynamic Interaction

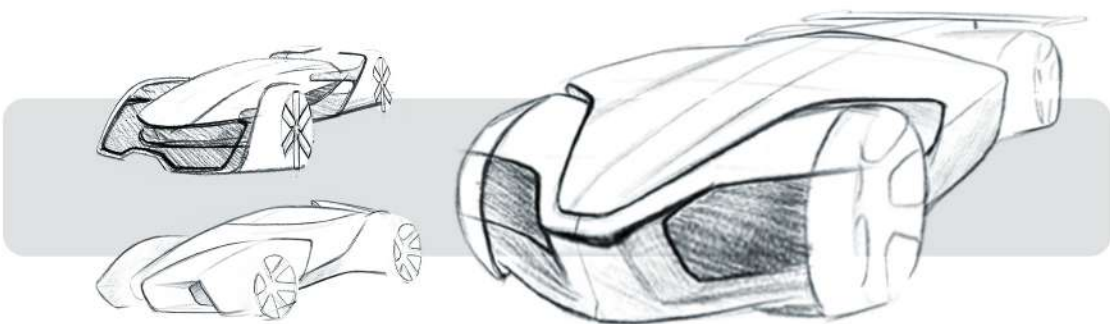
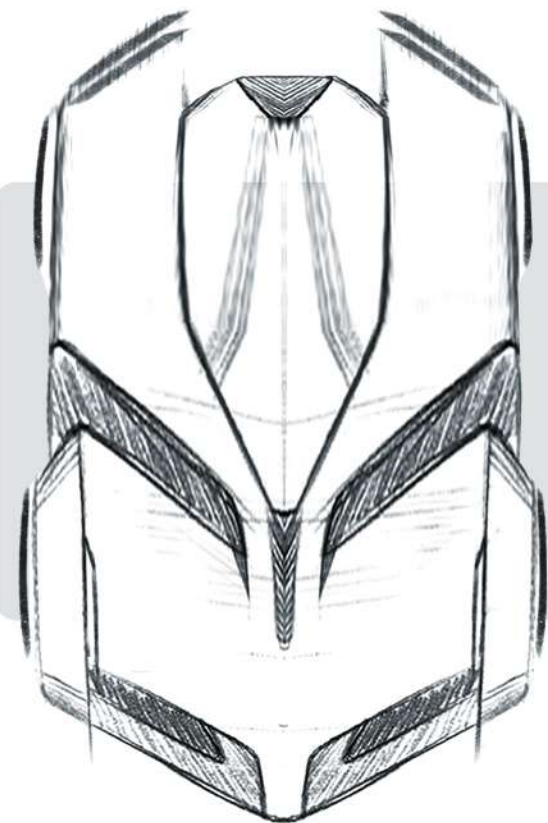



# Dream Racer

Geometric Boldness is a design language that expresses three core elements of American design: simplicity, modernity, and straightforwardness.

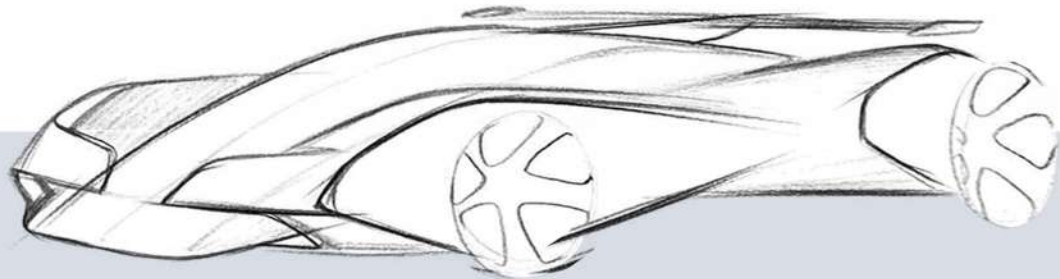
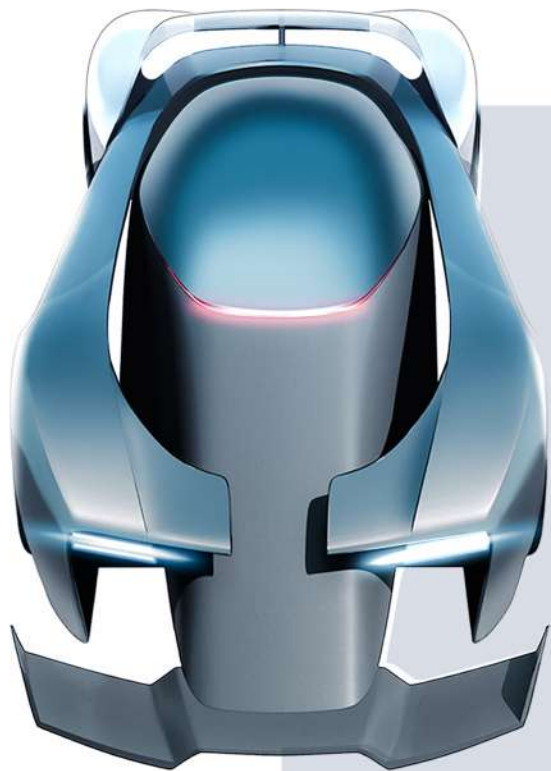
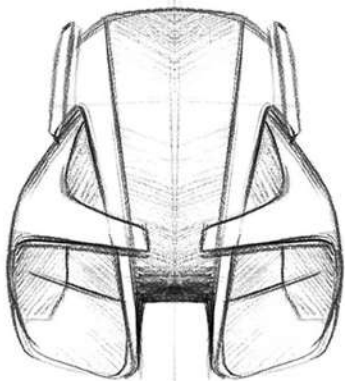

## ■ Geometric Boldness





## Dream Racer

Inspired by the ignition and ascent of a spacecraft, the 'Propulsive' design language expresses pure energy, acceleration, and a forward-driving spirit in the sports car.

■ Propulsive

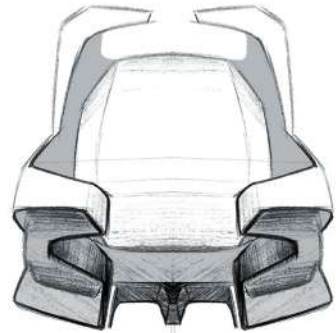
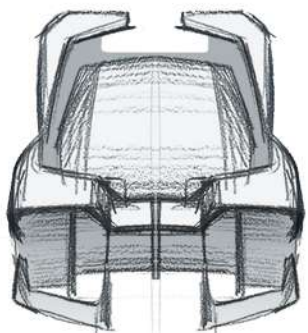
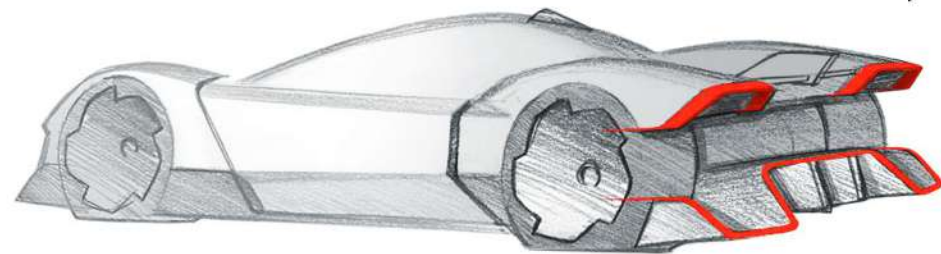

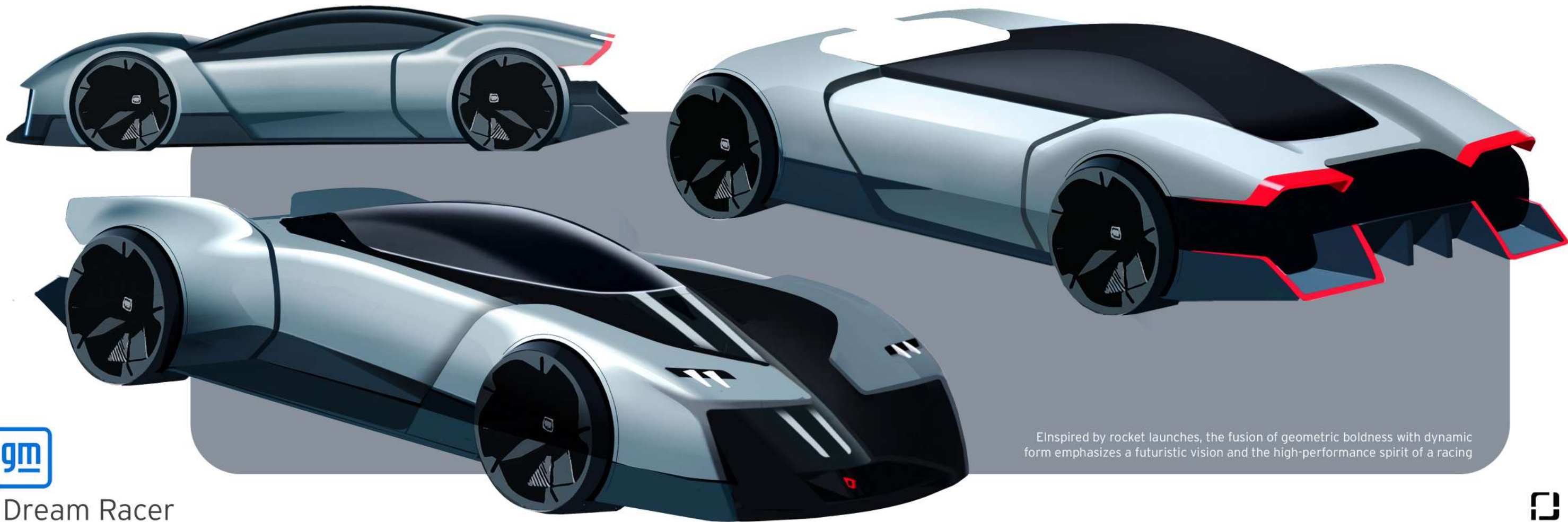

Inspired by rocket launches, the fusion of geometric boldness with dynamic form emphasizes a futuristic vision and the high-performance spirit of a racing



Dream Racer





## Dream Racer

Every design element of this vehicle serves a real function, contributing to the exotic racing experience—not just existing for appearance.



1. The front deployable spoilers help with downforce and braking.



2. The headlights are designed to help the aerodynamic of the vehicle.





# Dream Racer

The vehicle added entertainment elements such as video games to the track-only high-performance

■ Final Design

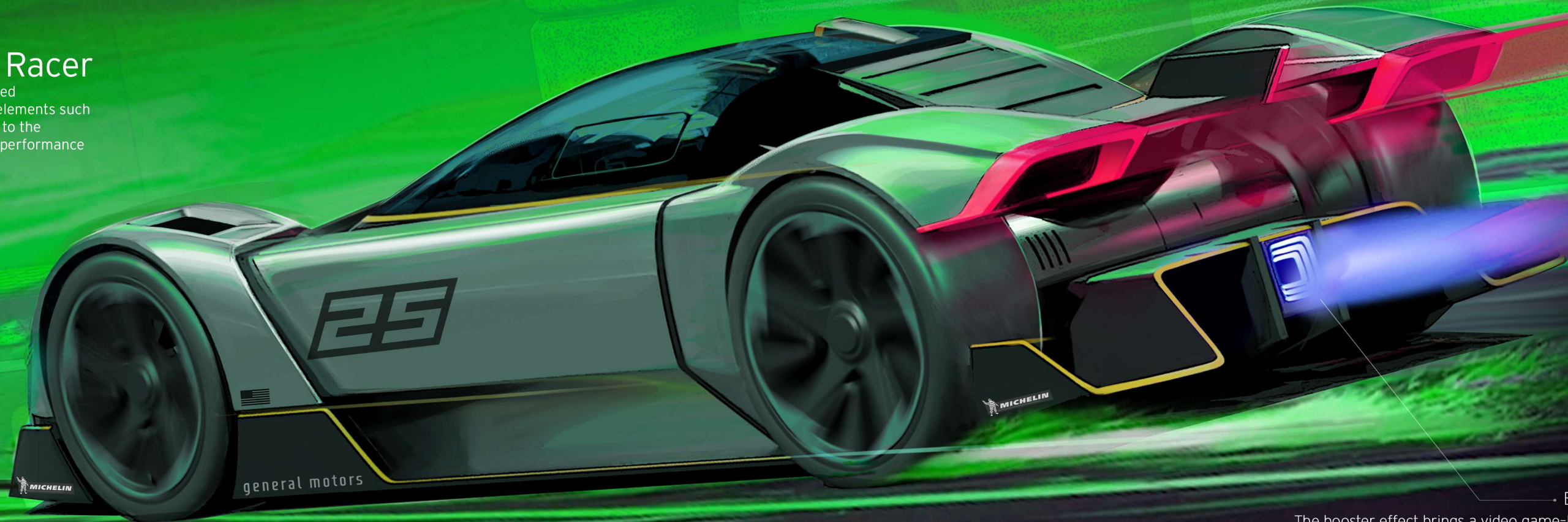

Booster Effect

The booster effect brings a video game-like sensation to real-life racing, enhancing the driver's enjoyment.





## Dream Racer

We all need to escape the seriousness and competitiveness of daily life from time to time. This vehicle offers the driver a sense of joy in response.

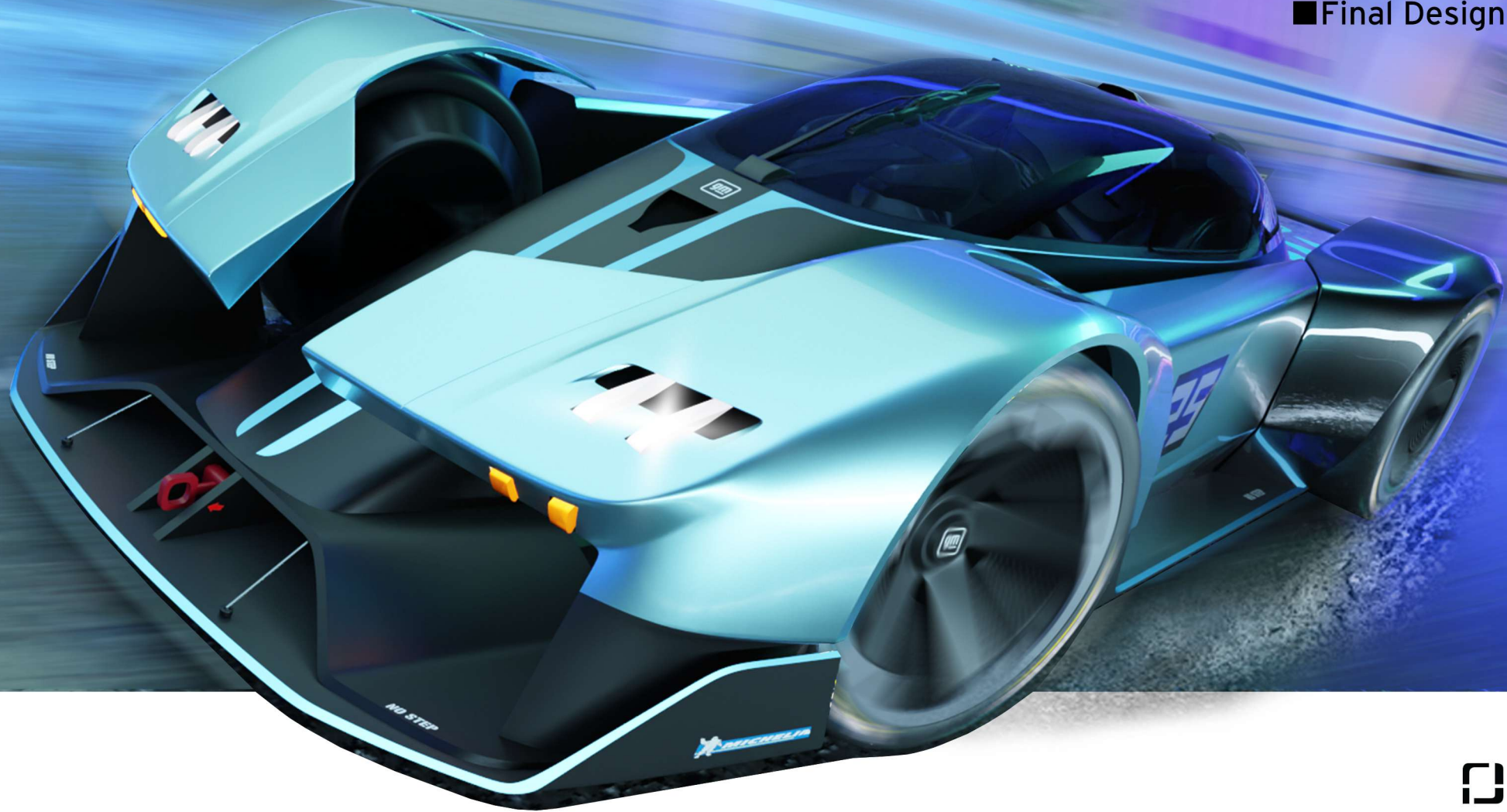

■ Final Design





# Dream Racer

The rear design, inspired by a rocket launch, emphasizes the powerful output that this vehicle unleashes.



Final Design





## Dream Racer

The rail structure located between the driver's seat base and the vehicle body enables the movement of the driver's seat.

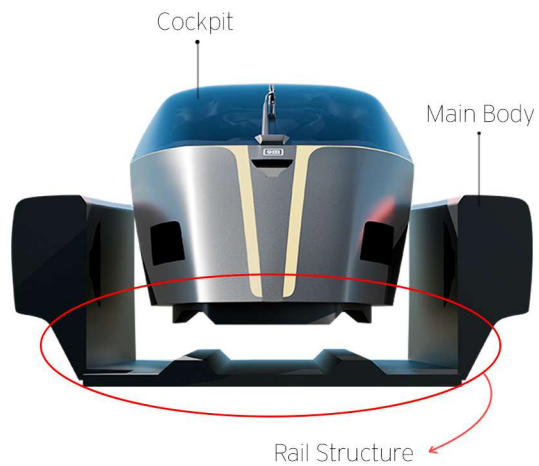



## Dream Racer

The vehicle's unique canopy-style doors and lighting effects, rarely seen in everyday cars, offer drivers a sense of excitement and enjoyment.

### 1. Lighting Effect

The lights mounted on various sides of the vehicle provide visual enjoyment to both drivers and spectators through a range of effects.



### 2. Canopy-Type opening Door

The canopy-style door, inspired by a fighter jet cockpit, provides the driver with easy access and a sense of openness when the vehicle is at rest.



Function





# Dream Racer

Dimension

Length : 4,651 mm

Width : 1,930 mm

Height : 1,048 mm

Wheelbase : 2,850 mm

■ Dimension

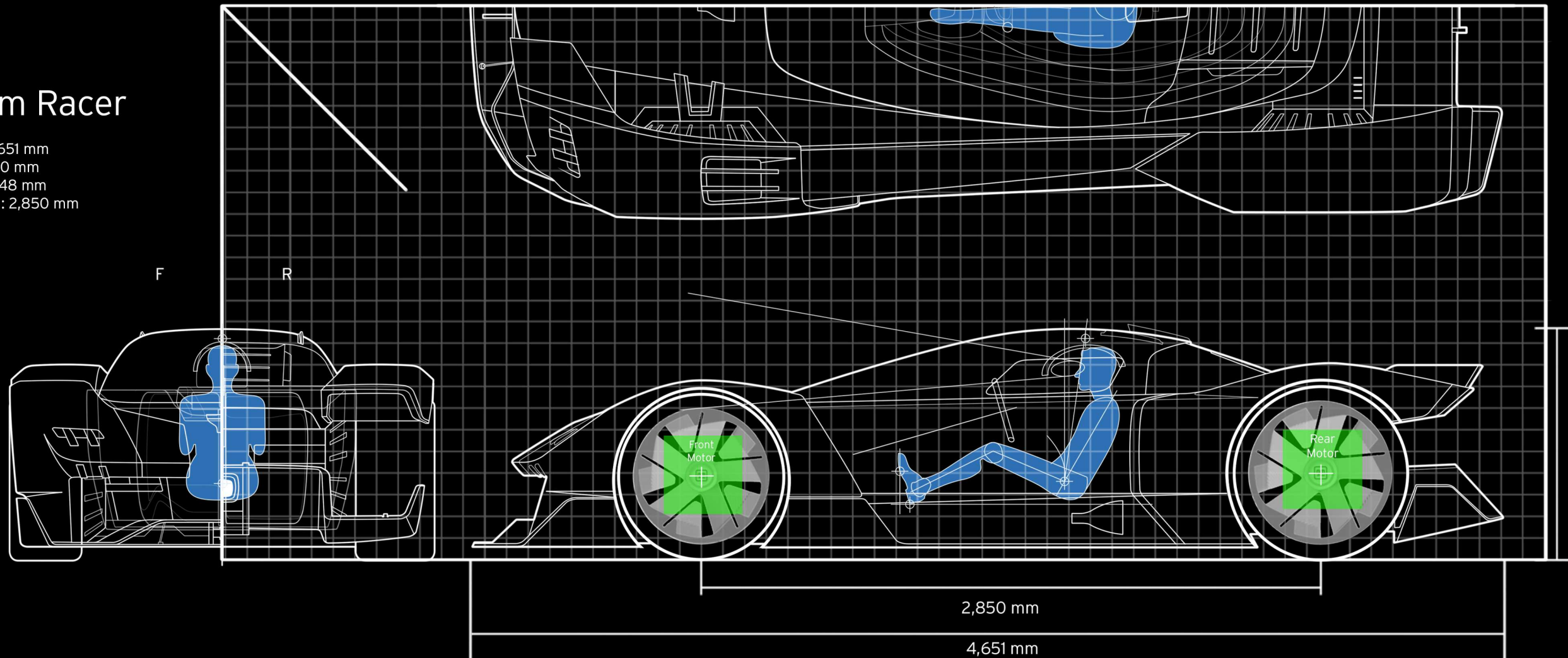



## Dream Racer

The use of gradient paint evokes a sense of dynamic speed—making the car look as if it's racing forward, even at a standstill.

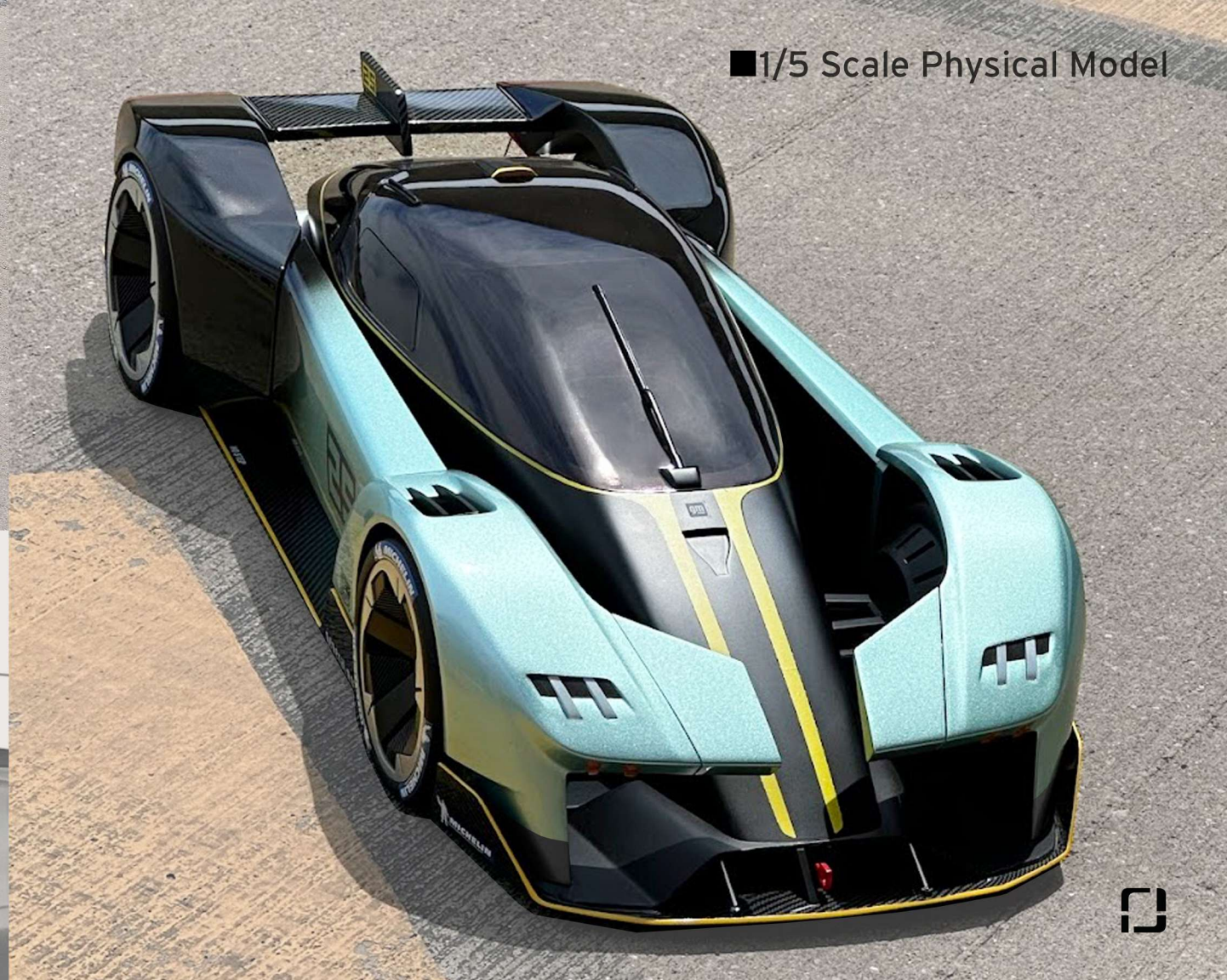

■ 1/5 Scale Physical Model



Ext Designer : Byeongmin Kim  
Int Designer : Woobin Park



Watch the full animation  
on Youtube



↑ Youtube video Link

# Jeep | Huntington

2040 Sunbathing Dating on your Jeep





1. Name : Jessica (26) / Brandon (31)
2. Location : Huntington beach, California
3. Job : Physical Therapy Assistant / Certified CrossFit Trainer
4. Pain Point : As an active couple who enjoys sunbathing, surfing, and off-road adventures, they often find that preparing for outdoor activities takes too much time and effort—packing gear, planning routes, and setting up once they arrive.



## Enjoy Outdoor Adventure without Preparation!



Concept Explanation : Designed for young couples, this vehicle enables carefree beach drives and sunbathing anytime, with no preparation needed. While most leisure activities require extra spending, this leisure-optimized vehicle offers worry-free enjoyment without added costs.



# Jeep®

## Huntington

Inspired by a lightweight chair designed for sunbathing, the vehicle features a canvas top that functions as a roof while driving and transforms into a sunbed when parked on the beach.



Paper Mock Up

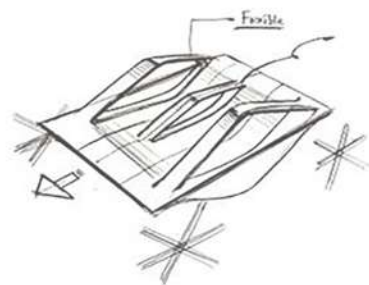
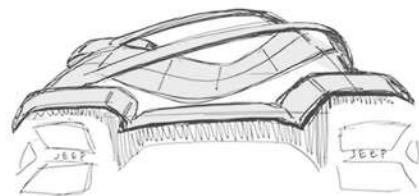
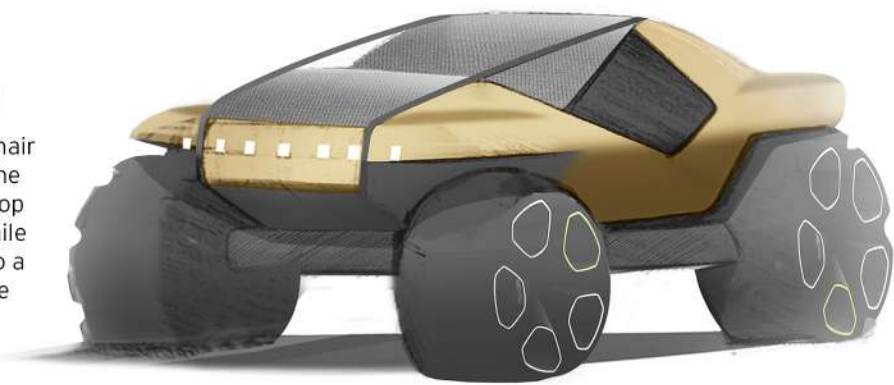
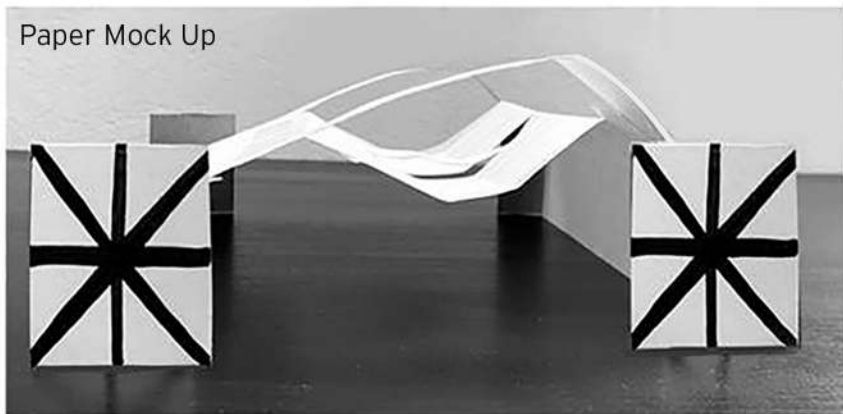

■ Ideation A (Windshield to Sunbed)



# Jeep®

## Huntington

Inspired by beach items such as surfboards and beach towels, the elevating rooftop made of canvas fabric offers users a comfortable and enjoyable sunbathing experience.

■ Ideation B (Elevating type Sunbed)

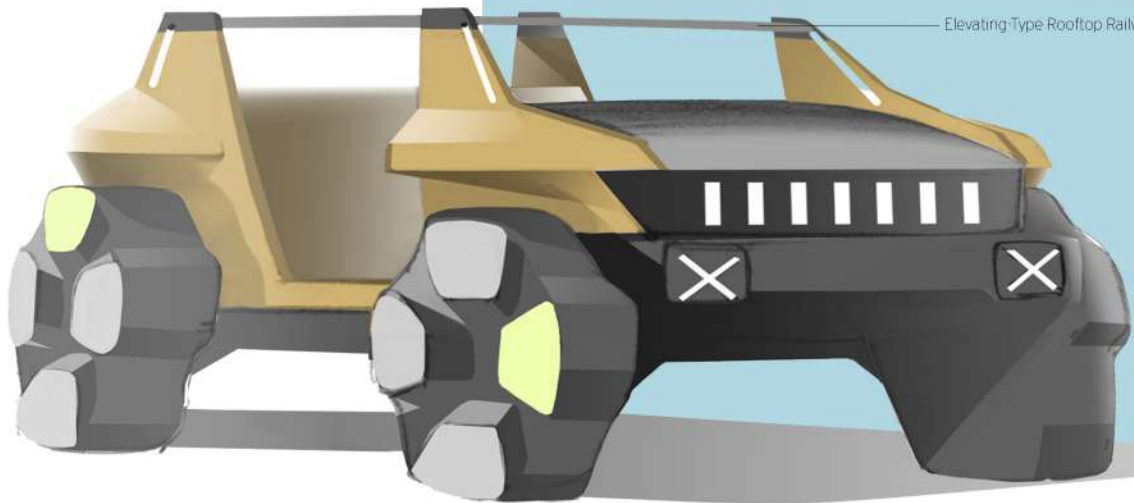
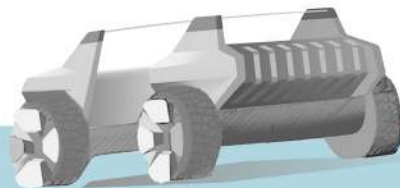

Elevating-Type Rooftop Railway



# Jeep®

## Huntington

The main point of this page is that the directions for driving and sunbathing are different.

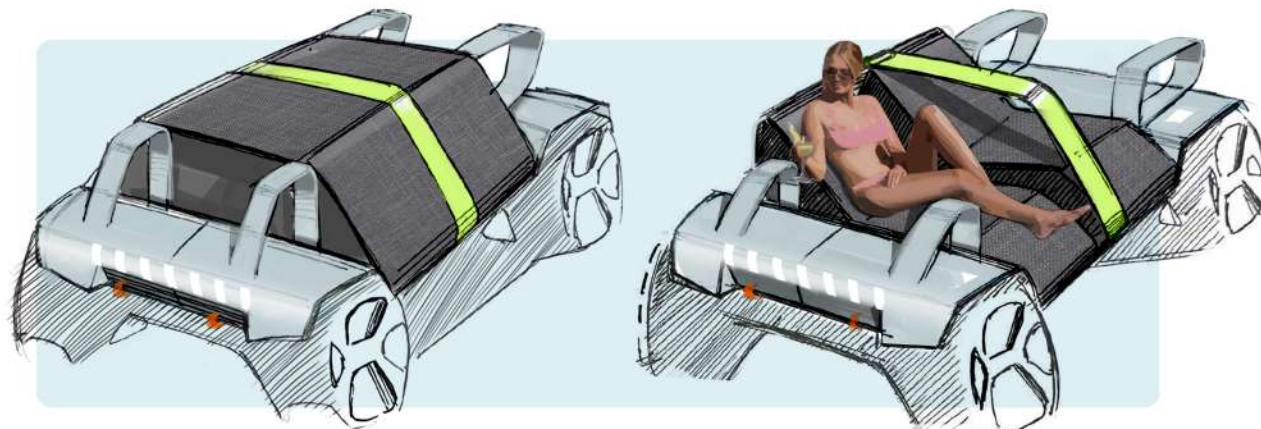

Driving Mode

Sunbathing mode

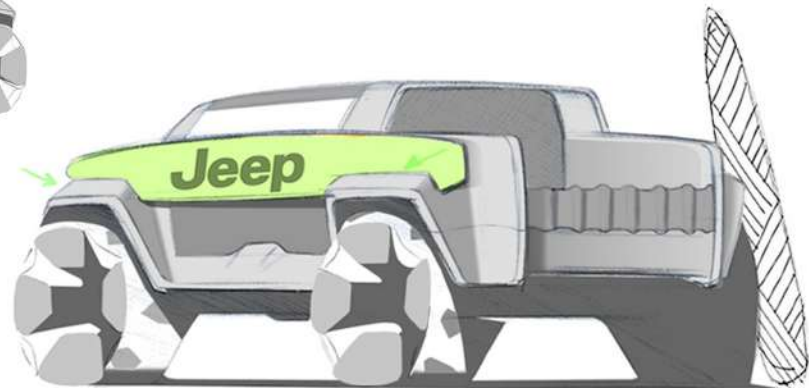
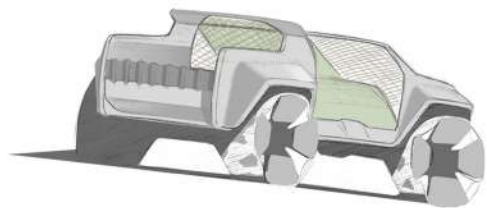

■ Ideation C (Chosen Theme)

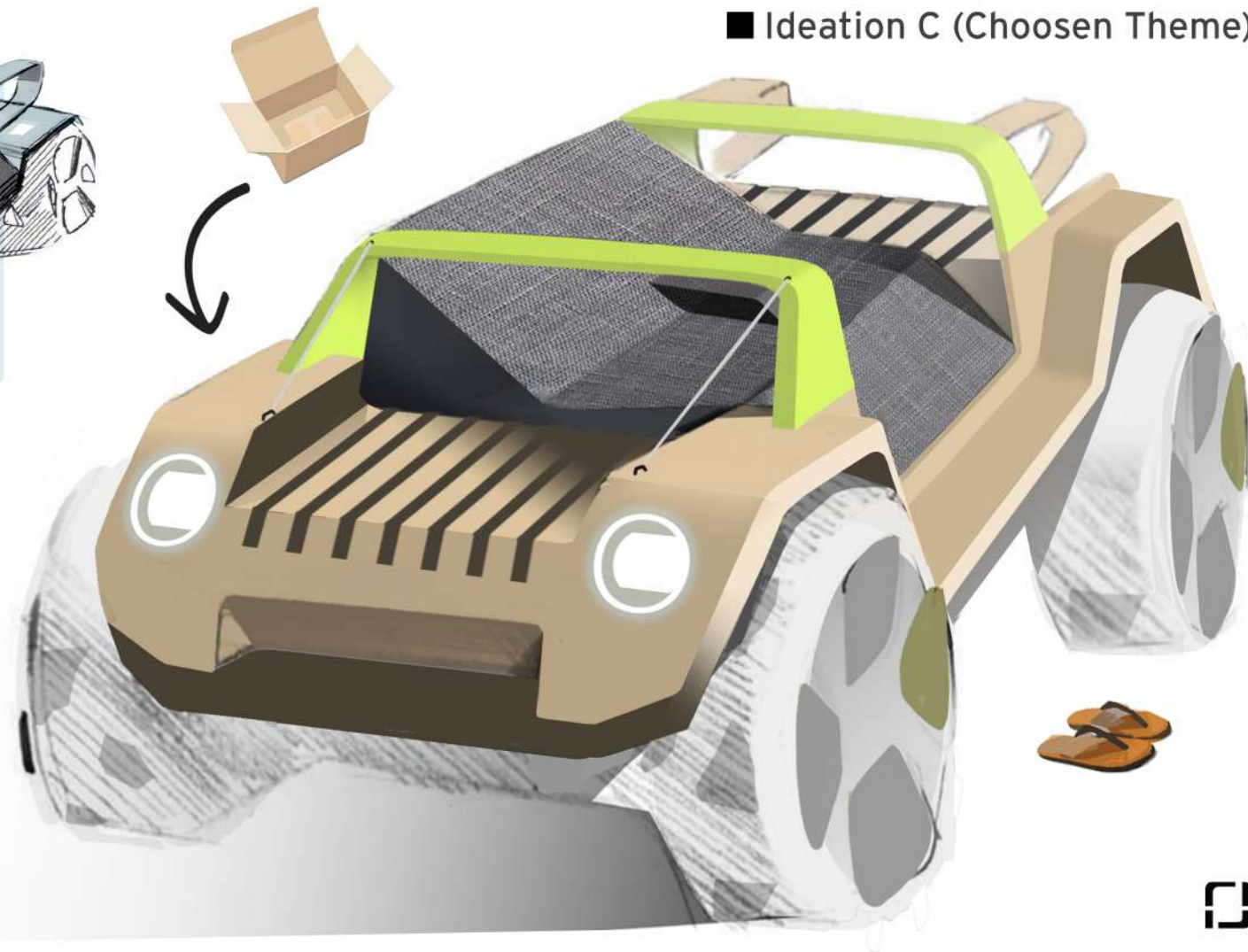

# Jeep

## Huntington

These development sketches show how sunbed concepts are incorporated into the vehicle's design.



■ Design Development



# Jeep®

## Huntington

Various design ideas are developed around the concept of combining driving and sunbathing experiences.

1. Sunbathing Mode  
The flexible rooftop transforms into a sunbed.

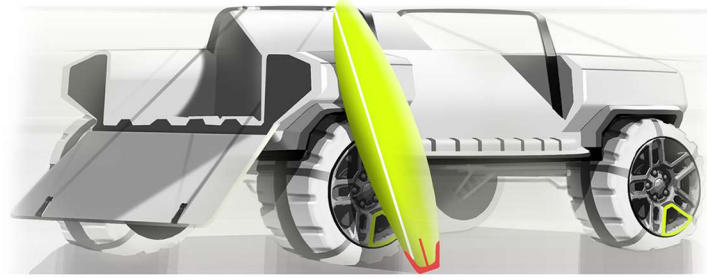

2. Driving Mode  
Surfboards are mounted on both sides of the vehicle and become integrated into the body when driving.

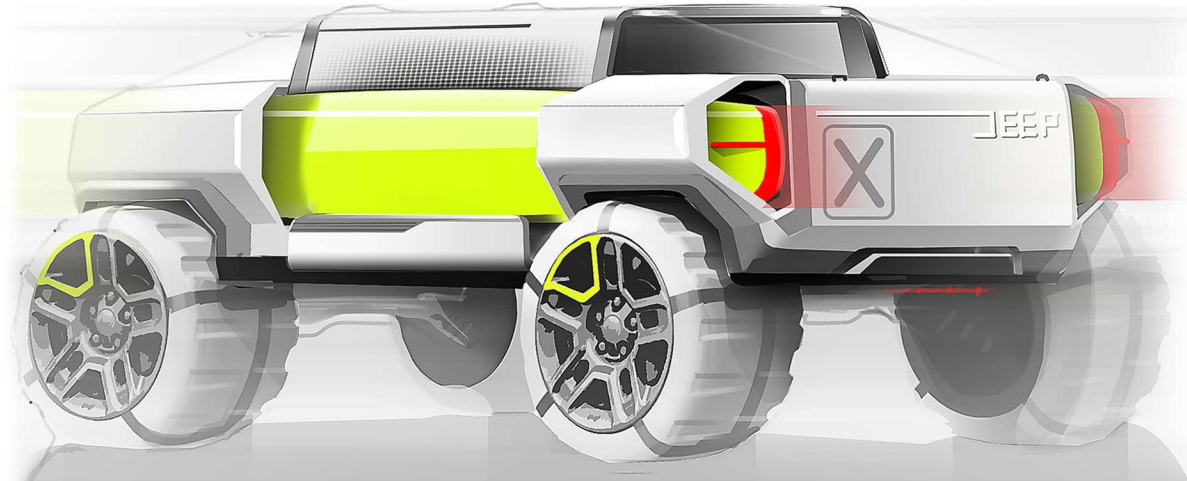

■ Design Refinement



**Jeep**  
| Huntington

Final Design



# Jeep®

## Huntington

Dimension

Length : 4,325 mm

Width : 2,327 mm

Height : 1,951 mm

Wheelbase : 3,192 mm

Autonomous Level : 5

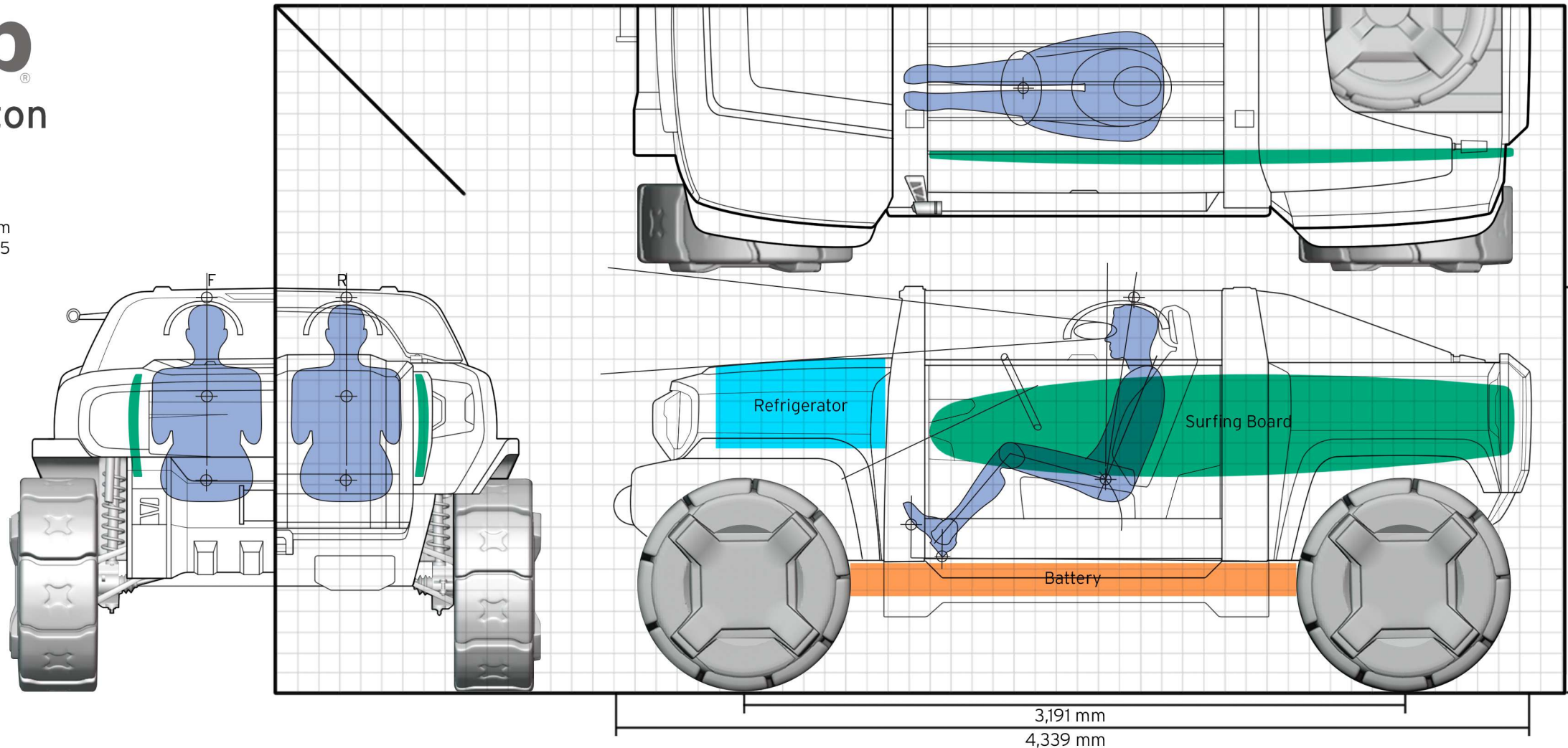

■ Dimension





## Sunbathing Mode

On the beach, User can make the flexible canvas top as a sunbed for enjoying sunbathing and take the surfing board from the side part for surfing.



# Jeep

I Huntington



## Terrain Mode

More than just a vehicle for on-road driving and sunbathing, it also excels at rock crawling and off-road performance.

■ Final Design



Surfing board  
Storage





Air-Conditioner

Wide Curved Shape Monitor

Digital Side mirror Camera

Detachable Bluetooth Speaker

Roof-Rail

Glove Box & Surfing Board Holder

## Interior Design

Inspired by surfboards, Jeep's seven-slot grille, this dashboard features a simple yet practical and iconic design.

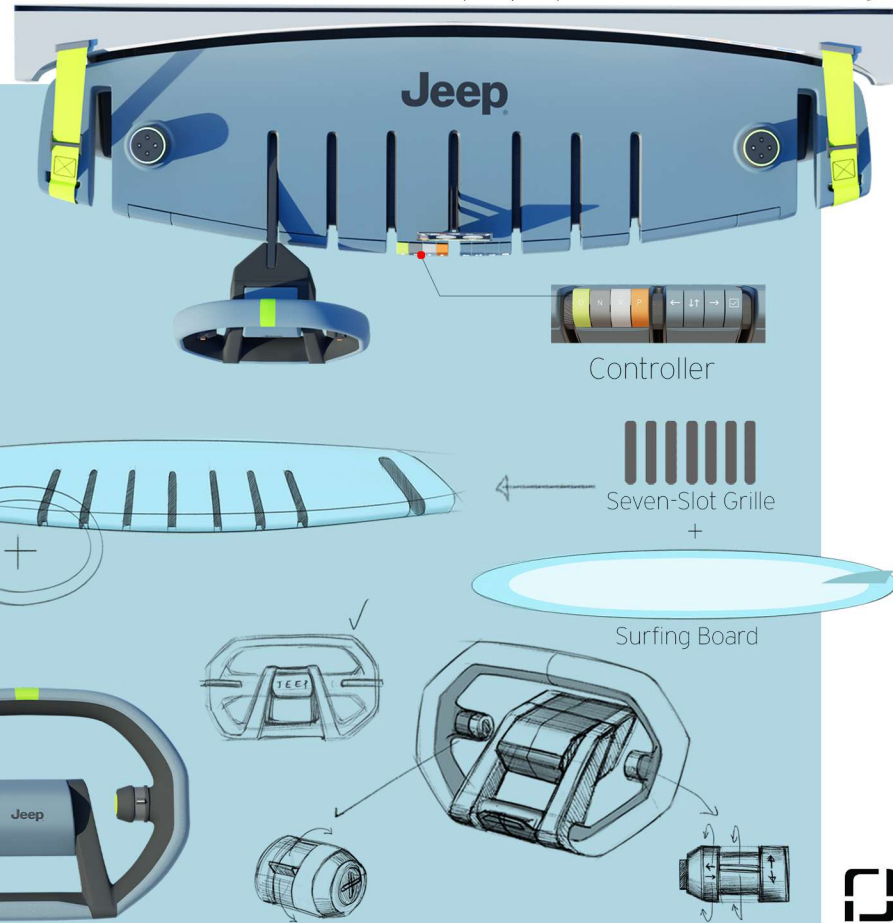

Controller

Seven-Slot Grille

Surfing Board



# Jeep® Huntington

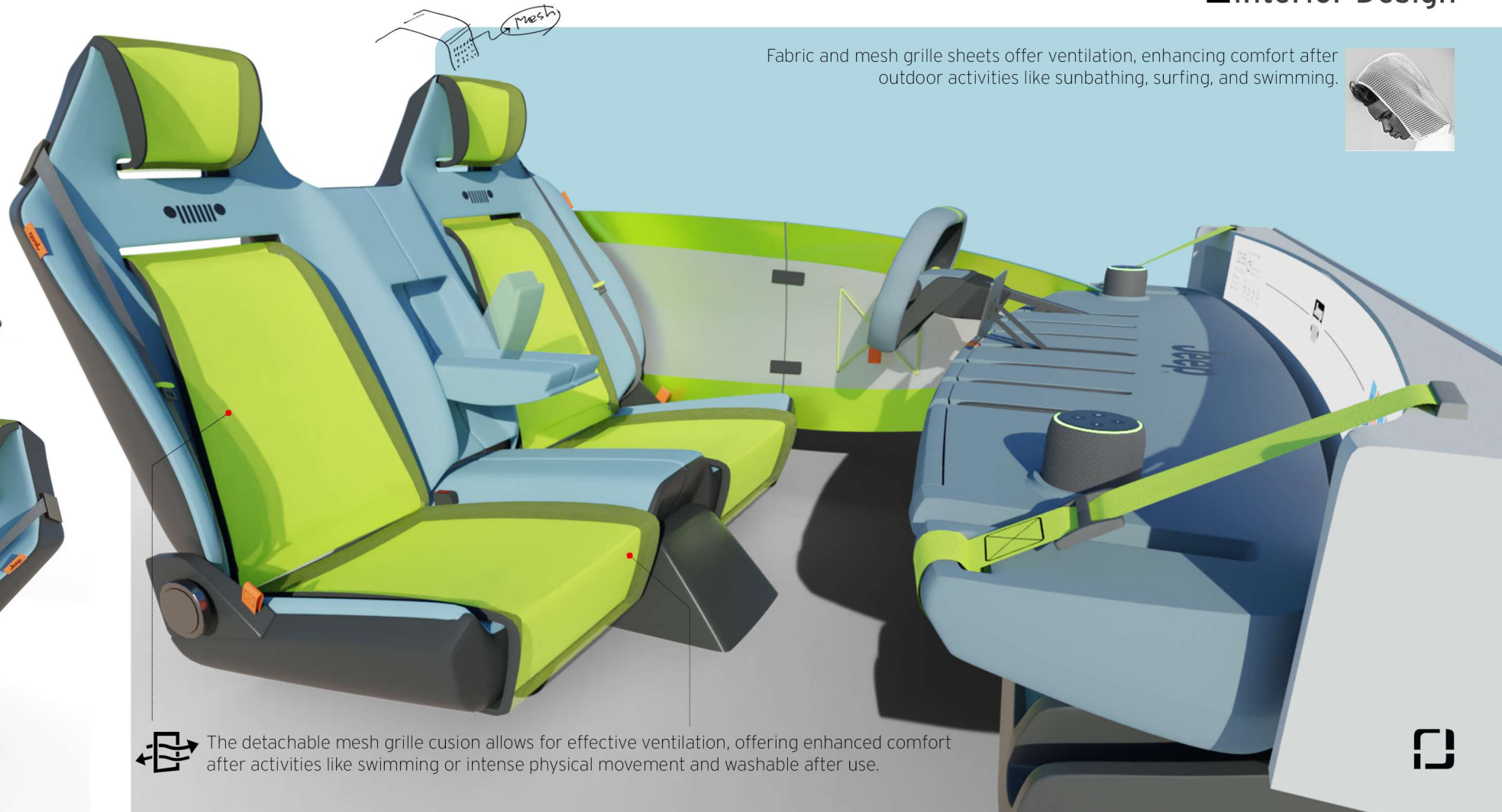
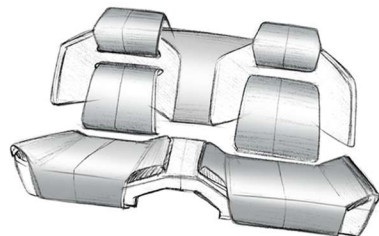
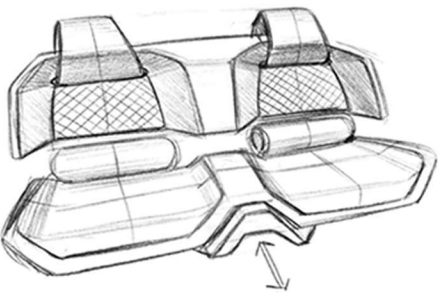
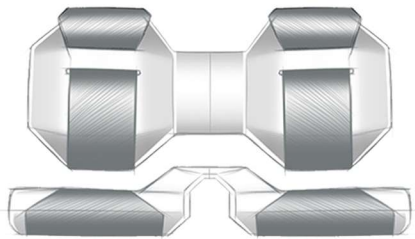

## Interior Design

Fabric and mesh grille sheets offer ventilation, enhancing comfort after outdoor activities like sunbathing, surfing, and swimming.



The detachable mesh grille cushion allows for effective ventilation, offering enhanced comfort after activities like swimming or intense physical movement and washable after use.



# Jeep

## Huntington

For passengers who enjoy sunbathing in the vehicle, features like refrigerators and steering wheel hangers add essential comfort and convenience.

Function



1. Front Refrigerator



2. Hanger for Steering Wheel & Bags



# Jeep®

## Huntington

The transition from a simple and intuitive three-step process to a sunbed is easy for any user to understand.

■ Sunbathing Mode

Sliding-Type Rail roof System



+



2-side Foldable Dashboard with Detachable Steering wheel

Roof Rail

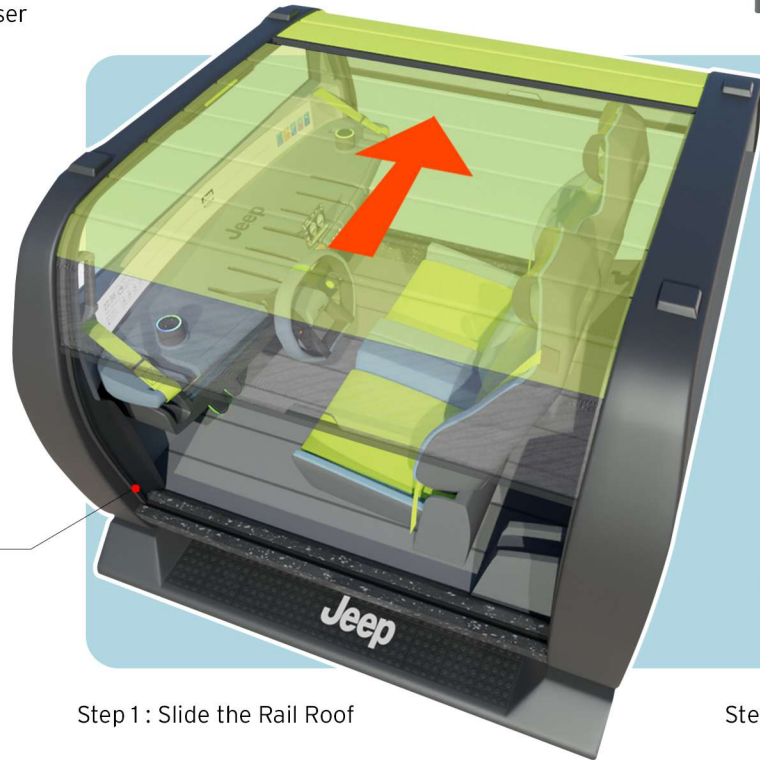

Step 1 : Slide the Rail Roof

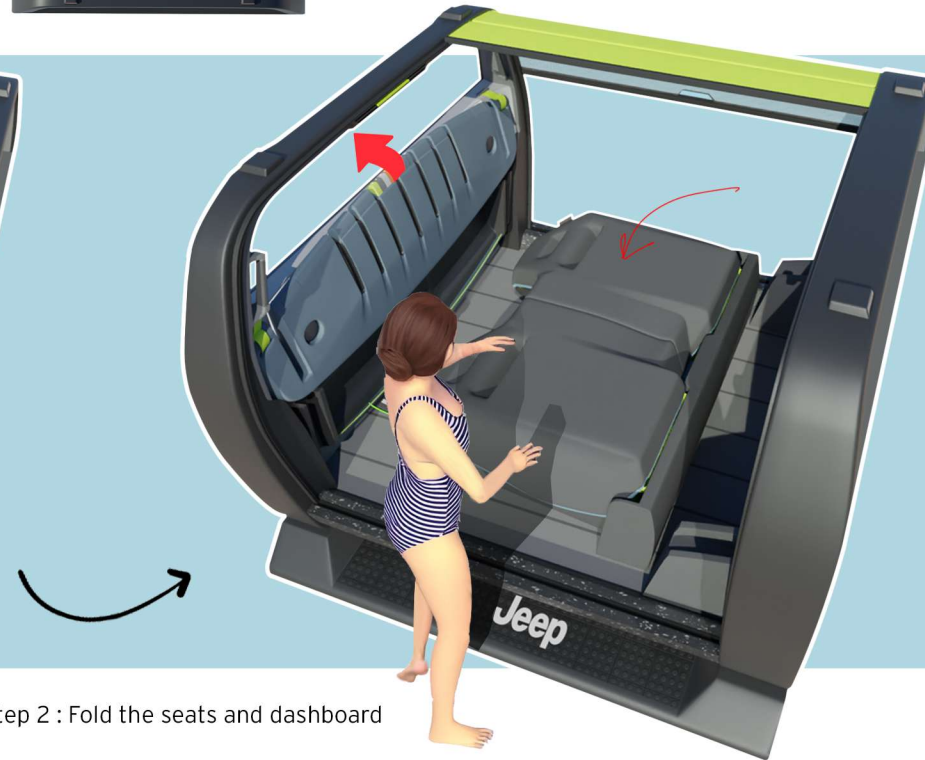

Step 2 : Fold the seats and dashboard



Step 3 : Outspread the rail roof & Enjoy sunbathing



# Jeep®

## Huntington

In driving mode, the foldable surfboard serves as a vehicle door, and when detached, it can be used for surfing in the sea.



Function Idea Inspired by a girl running with a SurfBoard on the beach



■ Driving Mode

This surfboard is made with high-strength materials and secure fixtures, ensuring reliable folding and full functionality as a surfboard.



Thank you so Much

Jeep





# Solaroid

The New 2040 hybrid Performance EV

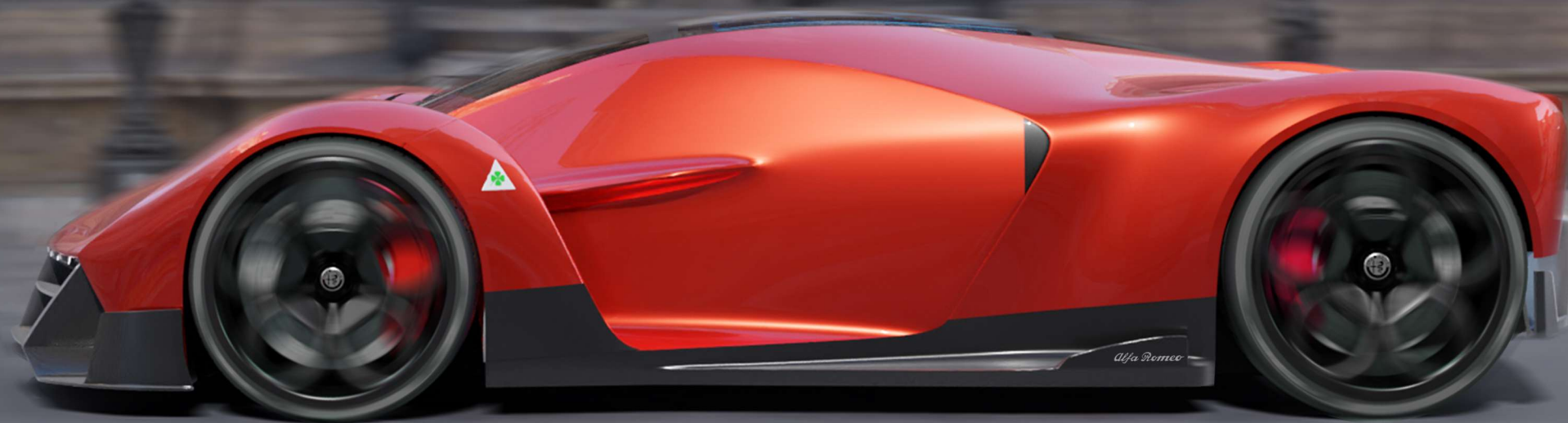



# Solaroid

Persona

# Sport Driving



# Nature & Sustainability



# Family



Bianca (40), Fashion Model  
# Milano, Italy



Needs

- She wants a car that reflects her identity: artistic, bold, and future-oriented
- She desires Eco-friendly. She's done compromising between beauty and eco-consciousness
- She enjoys performance driving and wants to enjoy and share this thrill with her two kids





**I Solaroid**

■ Solution

The new 3 seaters Hybrid performance EV

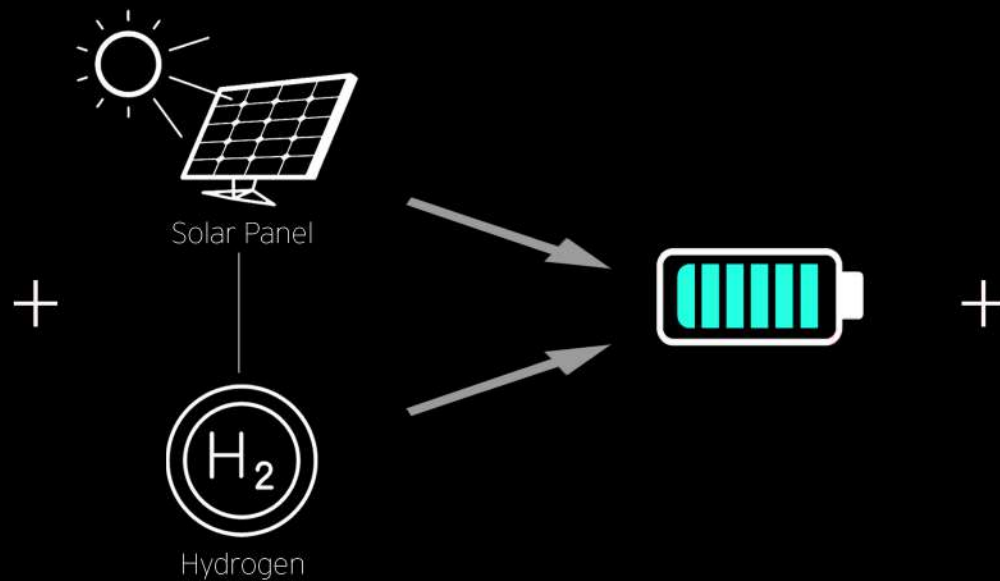

■ Performance

■ Eco-friendly and highly efficient

■ Shared Thrill





## Sculptural

Inspired by the bold and dimensional forms of sculptural speakers, the design expresses a futuristic identity with a strong and unmistakable character.



■ Direction A



This form gently echoes the silhouette of Alfa Romeo's iconic Quadrifoglio emblem within the side reflections, evoking a quiet homage to the brand's performance legacy.





## Voluptuous

The design features a voluptuous form language, where flowing surfaces and generous volumes come together to create an emotional and sensuous presence.

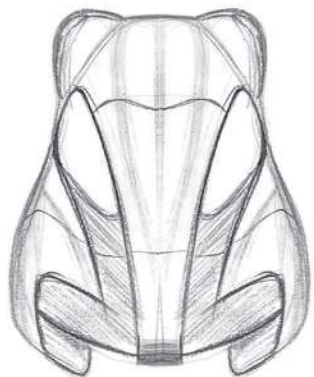

■ Direction C

Cap-Forward Design





## Dynamic Flow

The form, derived from a parallel slash motif, accentuates the vehicle's assertive performance and dynamic velocity through its precise and cutting contours.

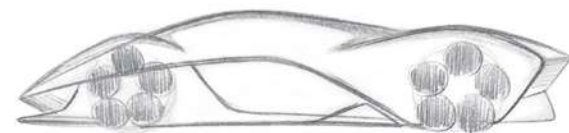
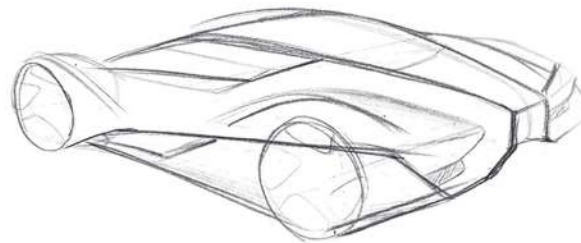

■ Direction B





## | Solaroid

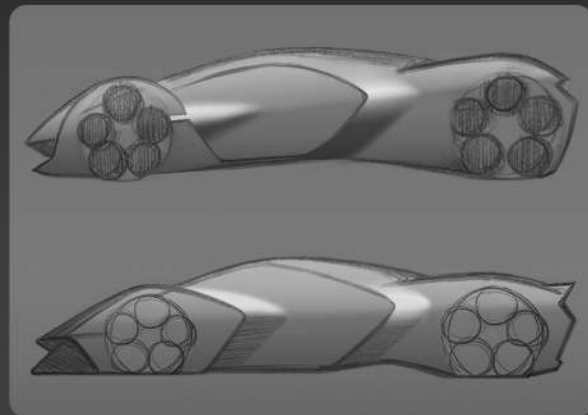

## ■ Design Refinement

The final side view expresses a distinctive character through the poetic interplay of Alfa Romeo's signature voluptuous volumes and bold, futuristic

*Alfa Romeo*





| Solaroid



■ Design Refinement

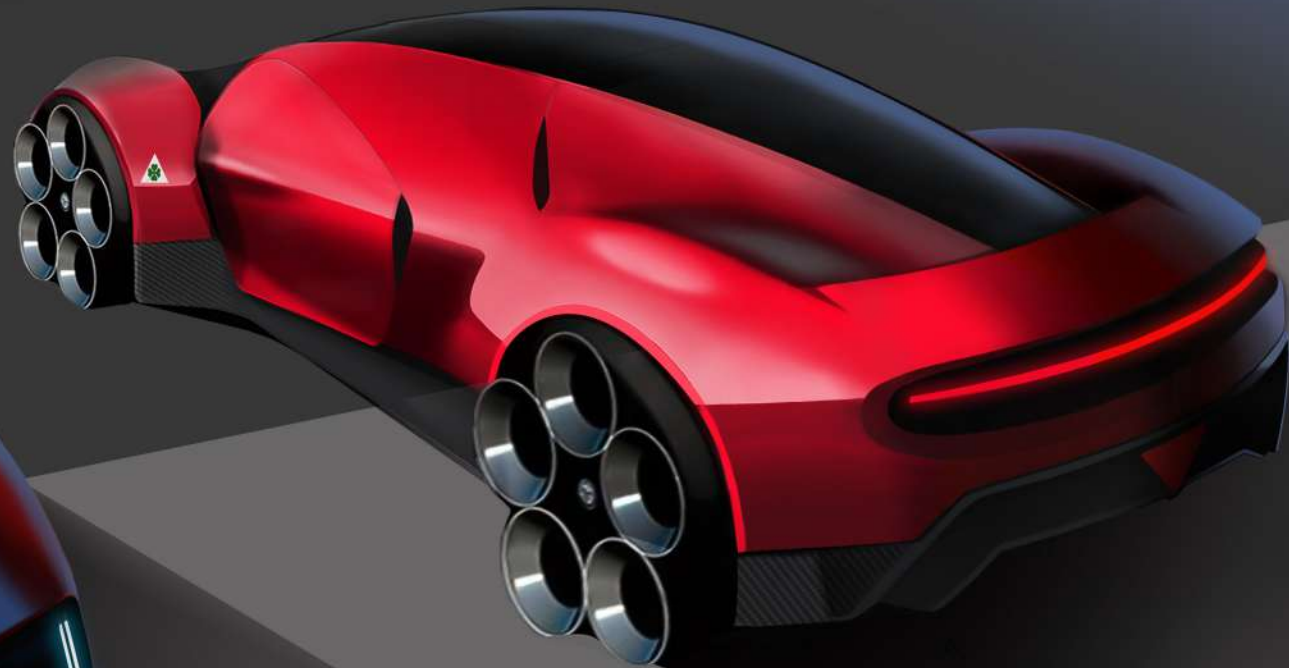
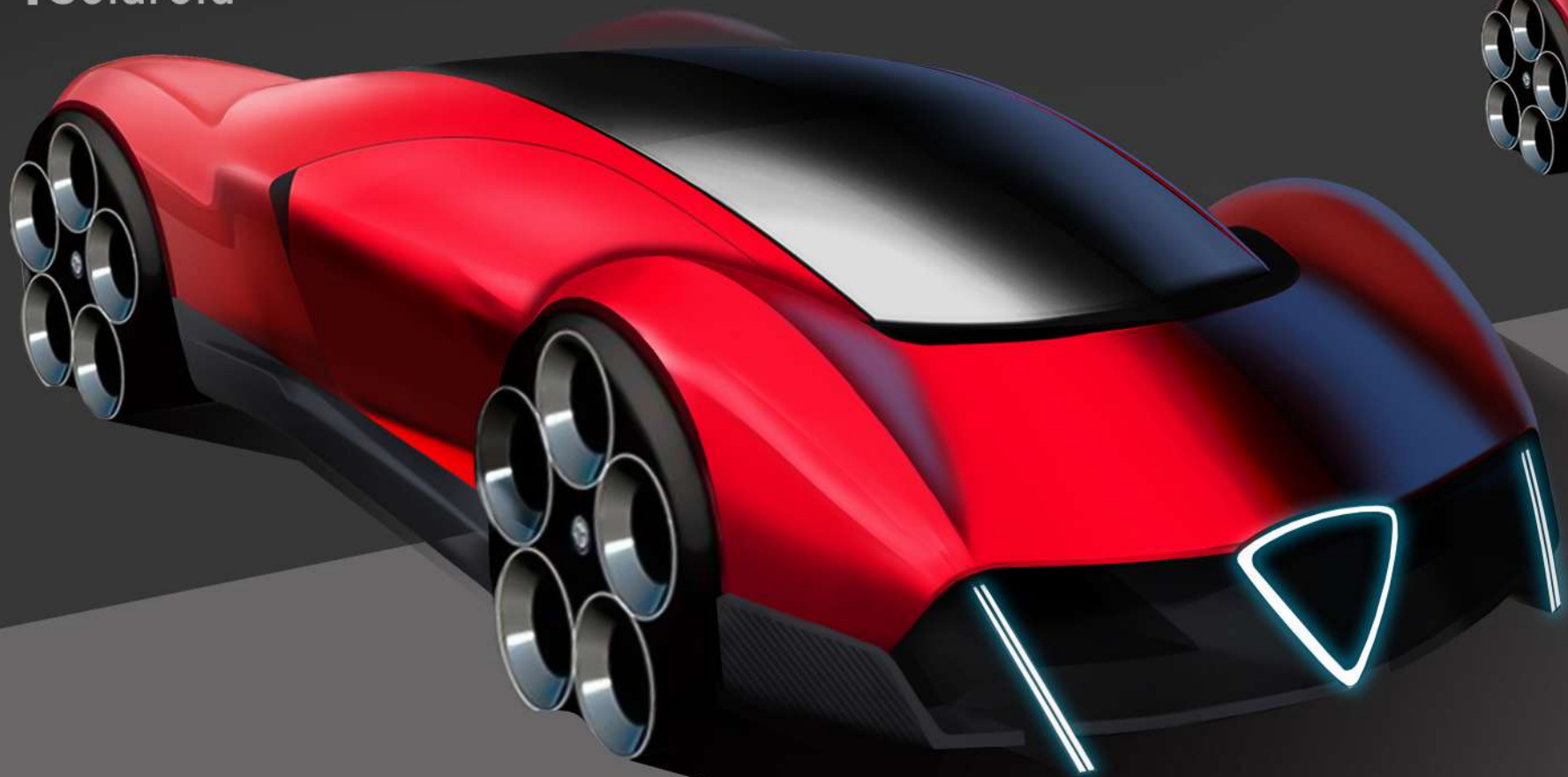

The front and rear fascias explore a variety of sculptural experiments, aiming to create forms that are playful yet full of character.





# Solaroid

Dimension  
Length : 4,865 mm  
Width : 2,200 mm  
Height : 1,188 mm  
Wheelbase : 3,191 mm  
Seats : 3 Seats

■ Dimension

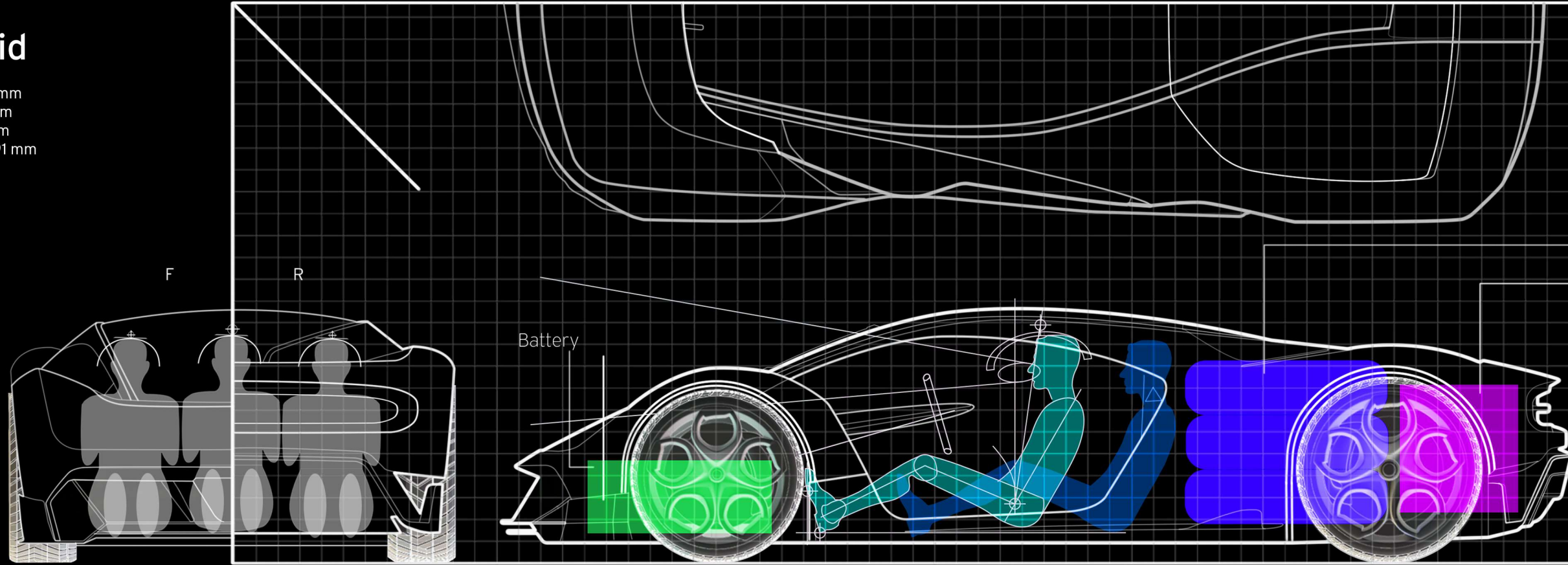



# Solaroid

'Solaroid' is a new hybrid system that integrates a high-efficiency solar panel with a hydrogen cell, eliminating battery charging time and delivering high performance, with a lightweight structure that improves overall vehicle dynamics.

## Powertrain system

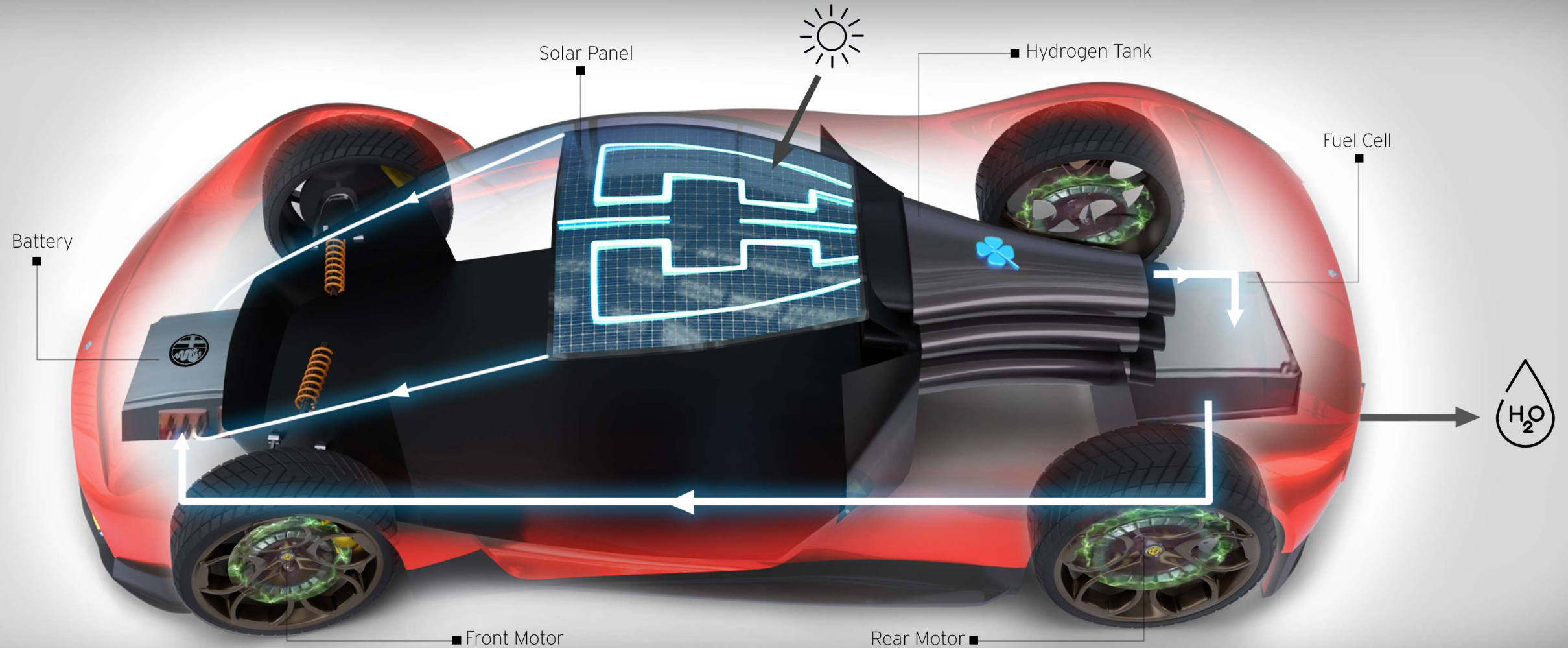



## Solaroid

A captivating red finish, voluptuous volumes, and uniquely distinctive shapes come together to harmonize futurism with Alfa Romeo's timeless heritage.



The front fascia echoes Alfa Romeo's signature grille, evoking the brand's distinctive character.

■ Final Design





## Solaroid

Two seamlessly flowing lines from front to rear emphasize both a sense of speed and the elegance of a smooth, continuous profile.



■ Final Design





# Solaroid

The harmony between sharp lines, voluptuous volumes, and the advanced solar roof captures both the heritage and the future of Alfa Romeo.



Scissor doors inspired by the Alfa Romeo 33 Stradale

Solar Panel Roof

Hydrogen Tank

■ Functions



Touch-type Door handle





# Solaroid

A design that embodies the famous principle 'form follows function' goes beyond mere aesthetic appeal, gaining its true allure through its actual performance.



Incorporating a flap-style brake design enhances braking efficiency and vehicle control.

■ Design Development

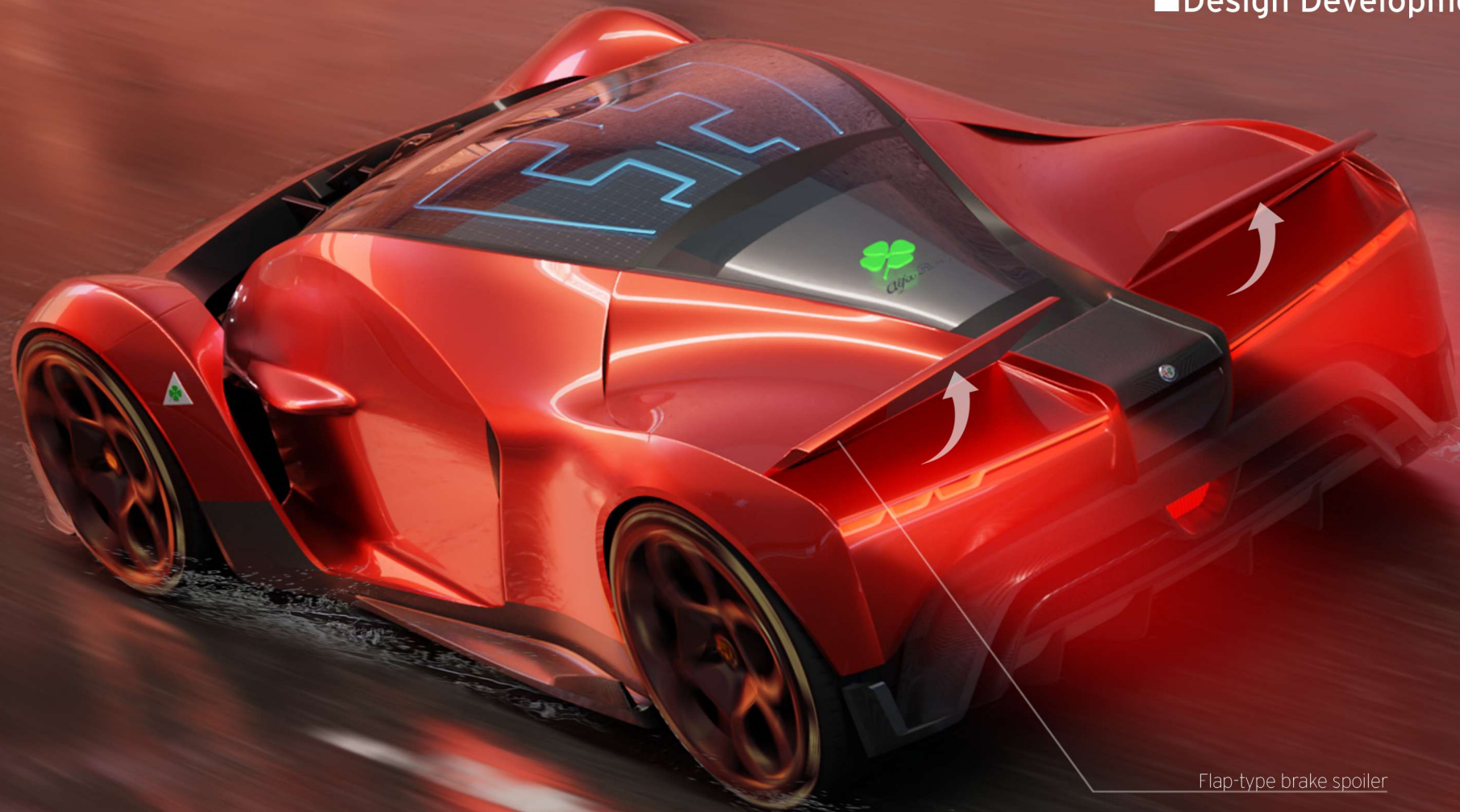

Flap-type brake spoiler





| Solaroid



Thank you so much





Nissan  
Ride-sharing Mobility  
2 weeks  
Ideation Project

Autonomous  
Ride-Sharing service  
inspired by Japanese 'Zen-garden'.



■ Concept



- Great Accessibility
- Enhanced Safety
- Enjoy a moment break in the busy city



# Zen-Mobility

"I have a very important meeting with a client today, but the buses and subways in Paris are too crowded, slow, and unsafe. What should I do?"



## Customer's Journey Map

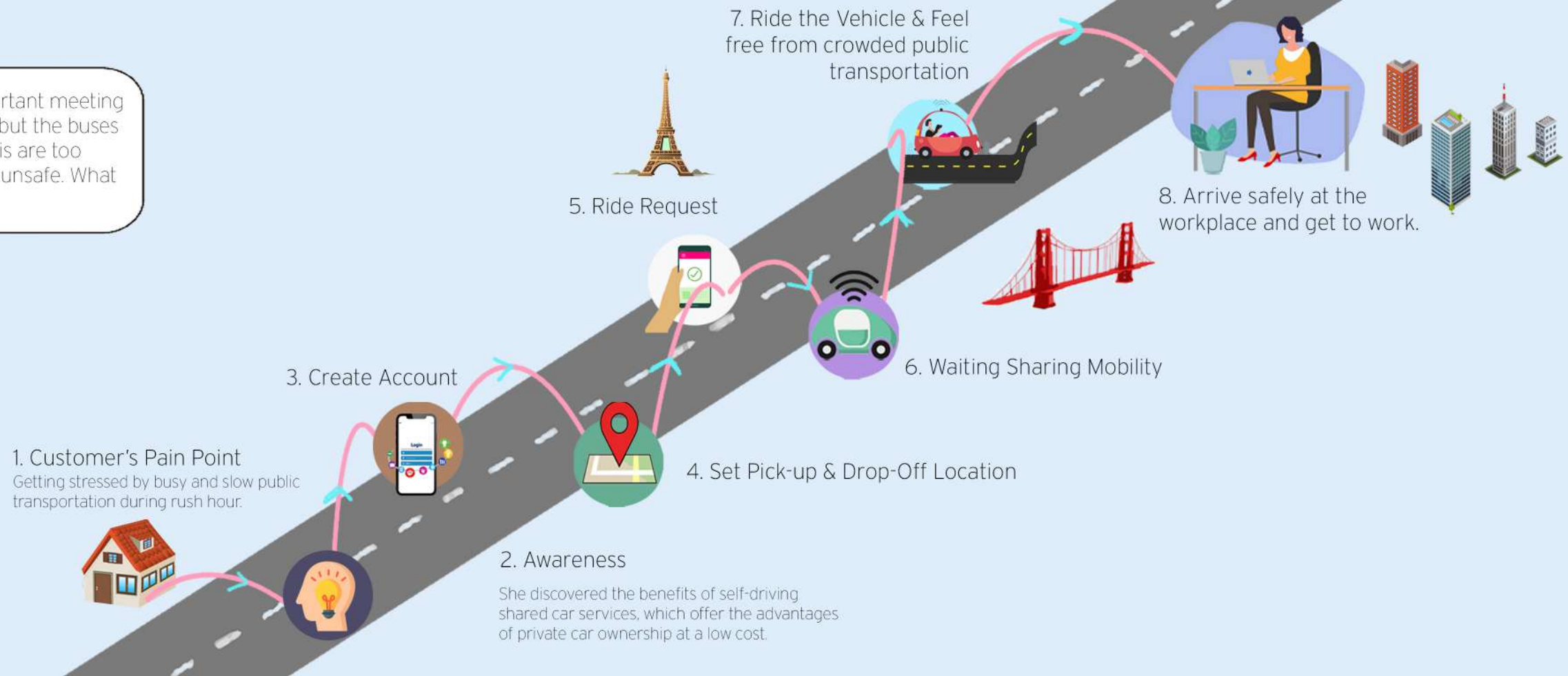

# I Wrap-around

Air Filter for providing clean air

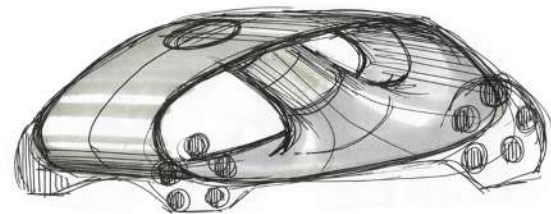

■ Direction A

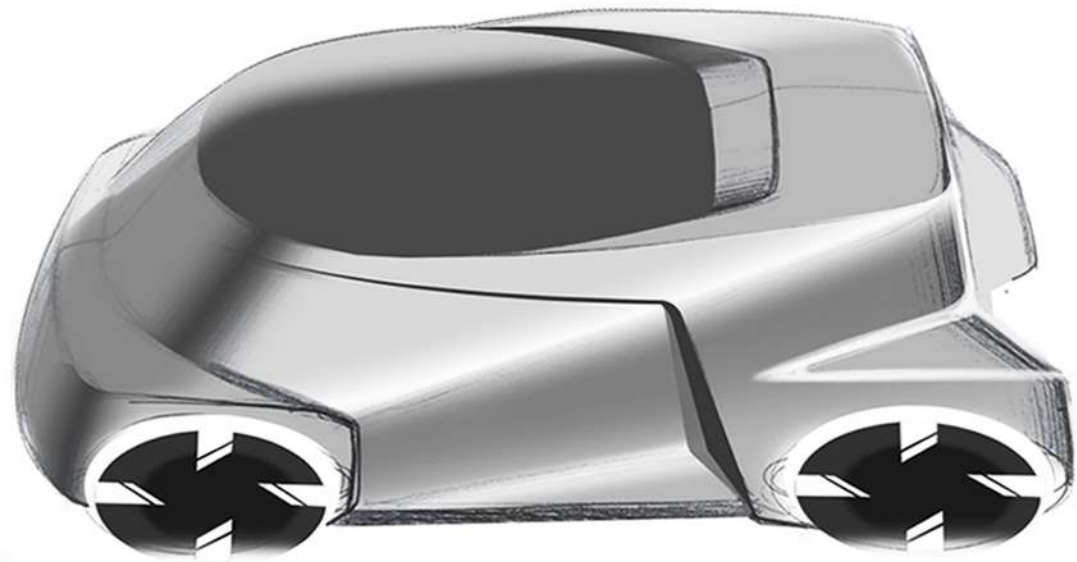
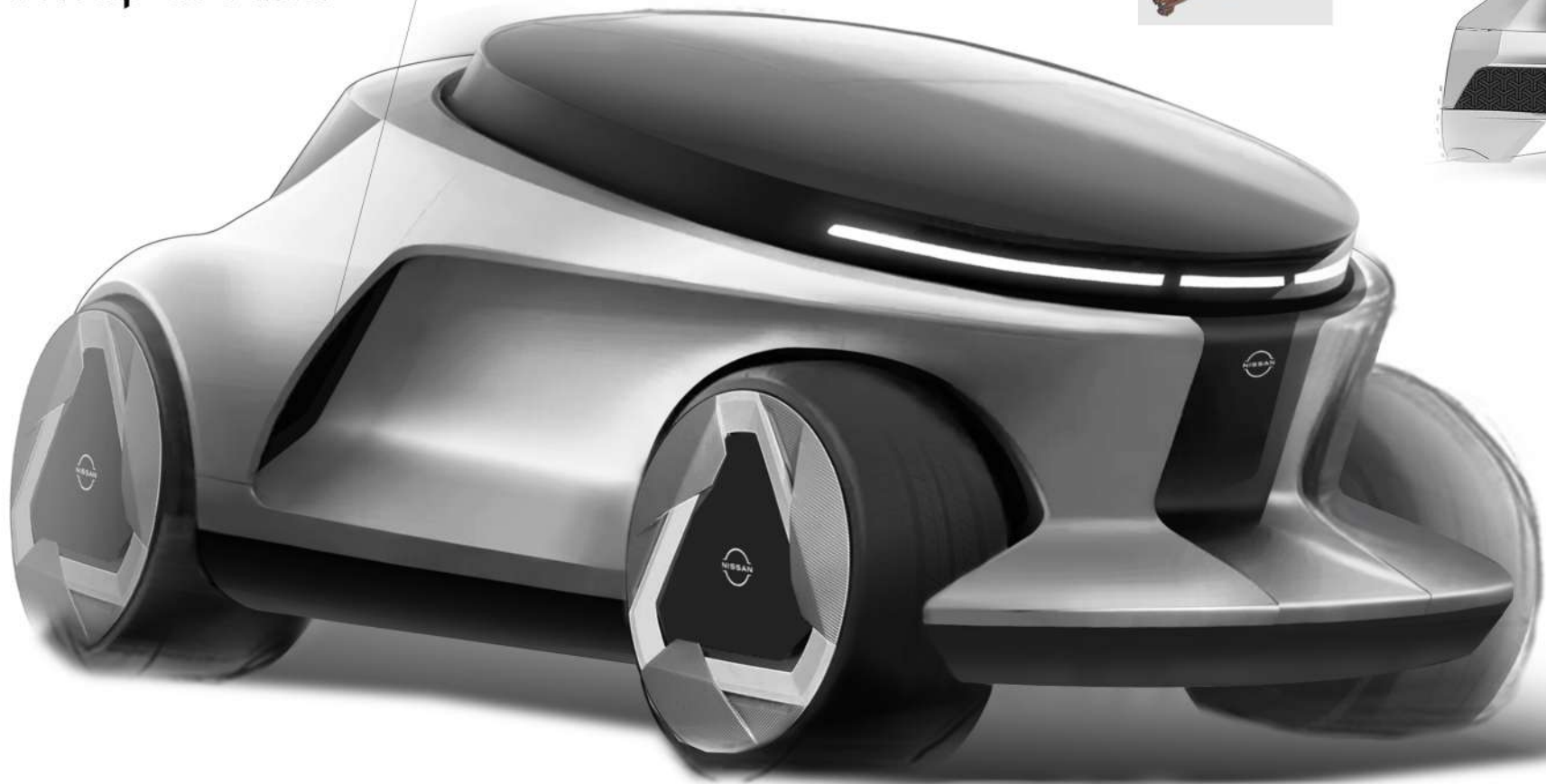

Inspired by sculptural seat that embraces the user, the design conveys a sense of comfort and protection.



# I Rugged

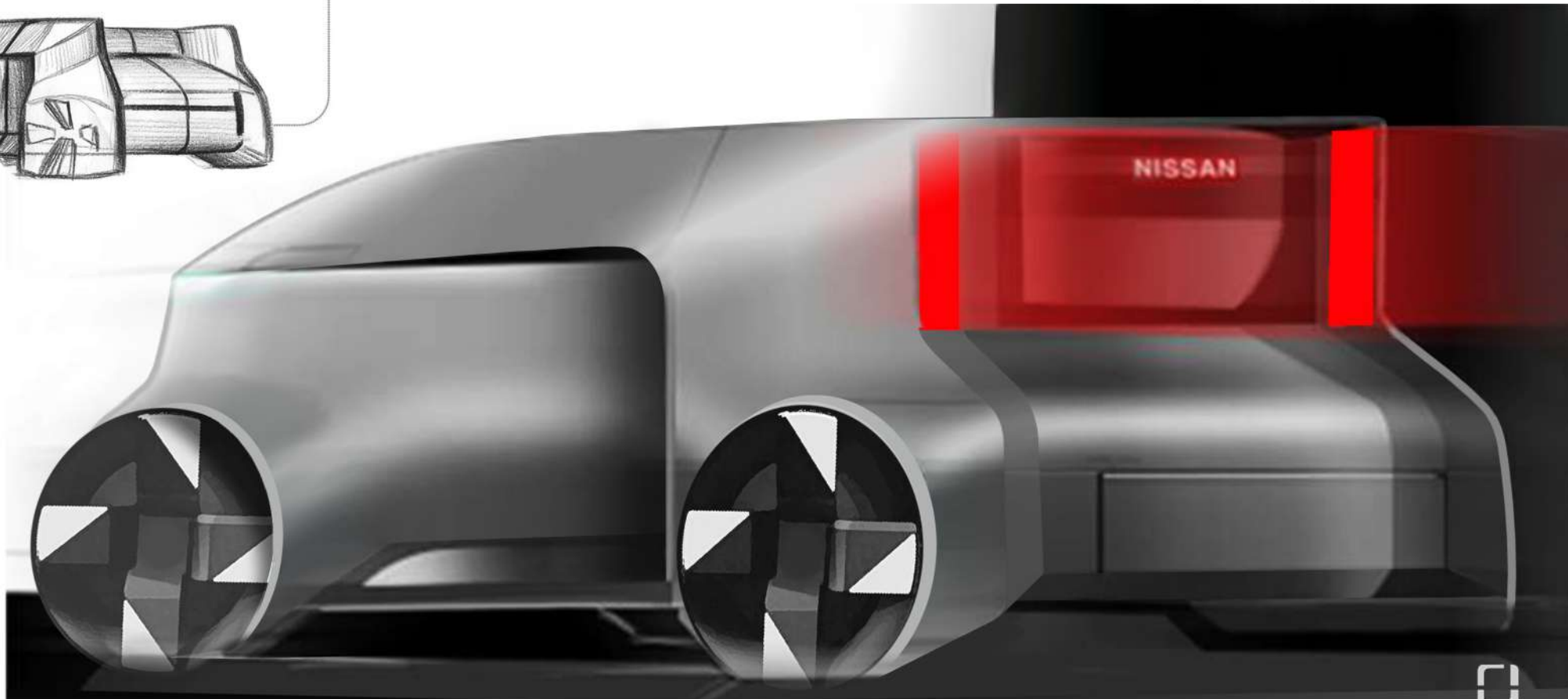
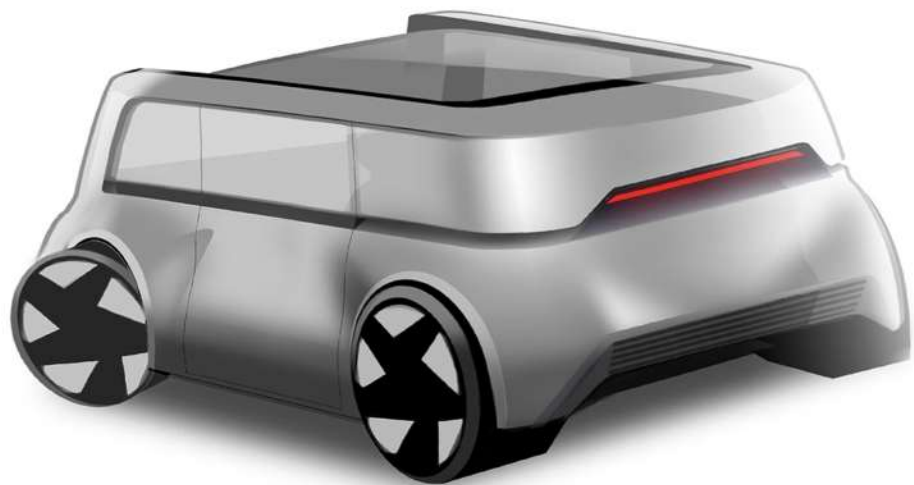
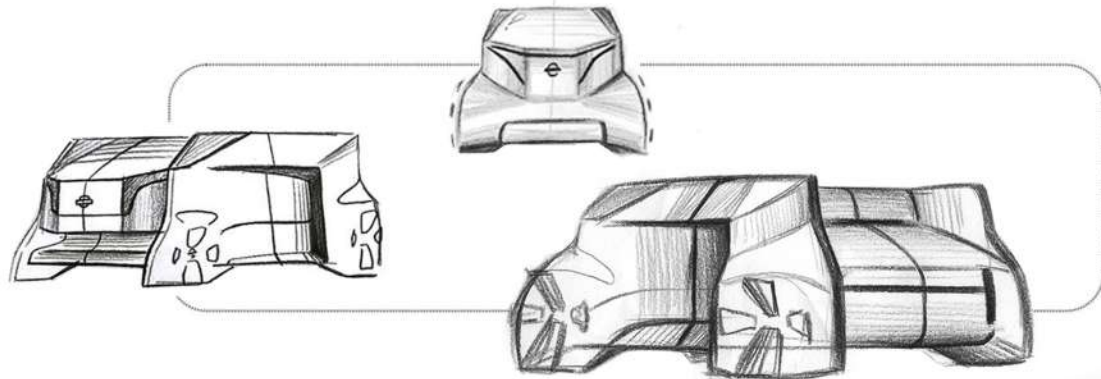

## ■ Design Development

The boxy-shaped design, which prioritizes space efficiency, reflects a vision of future-oriented mobility with its rugged and functional form.



■ Rugged

■ Direction B - Key Sketch

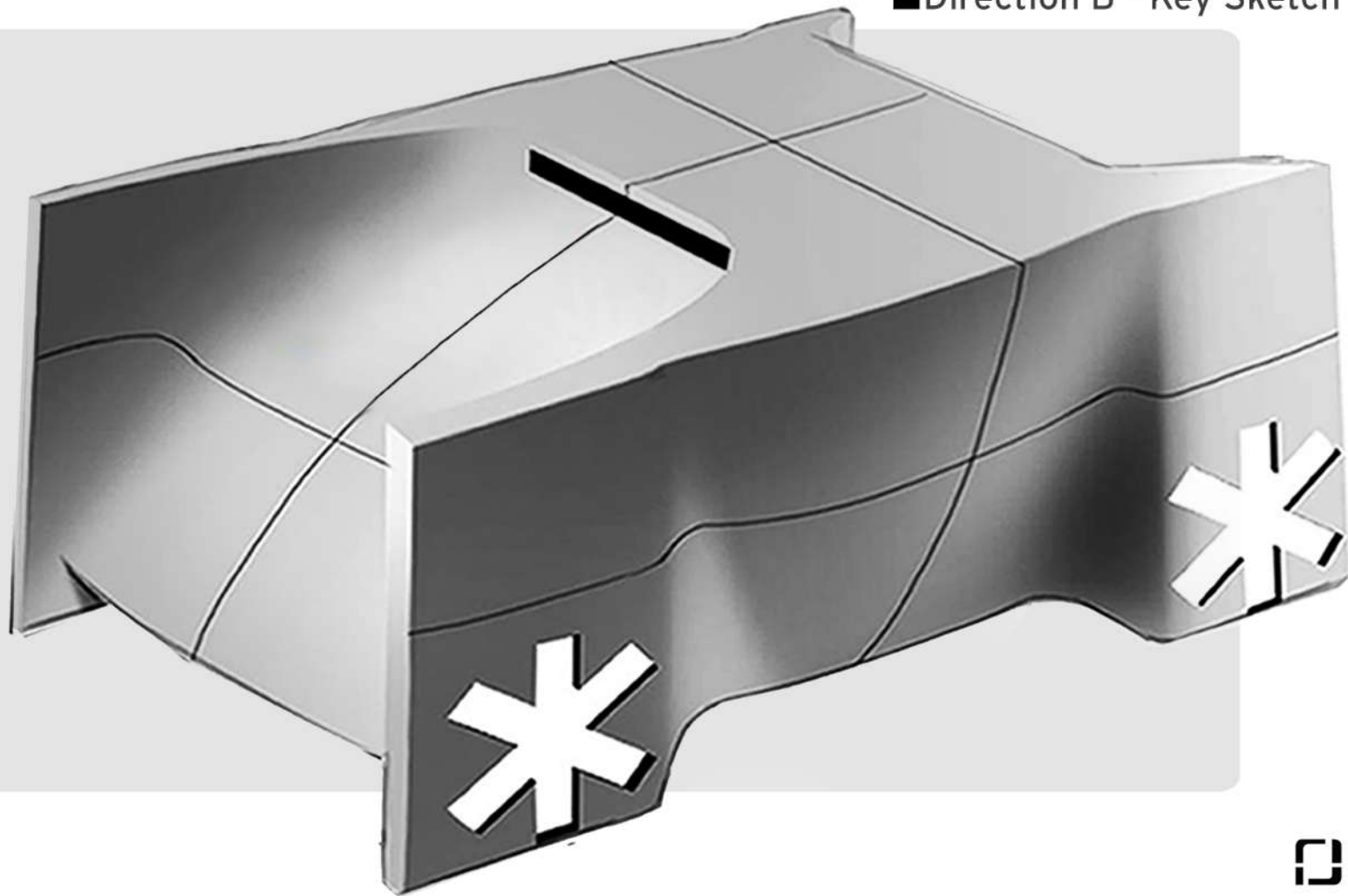
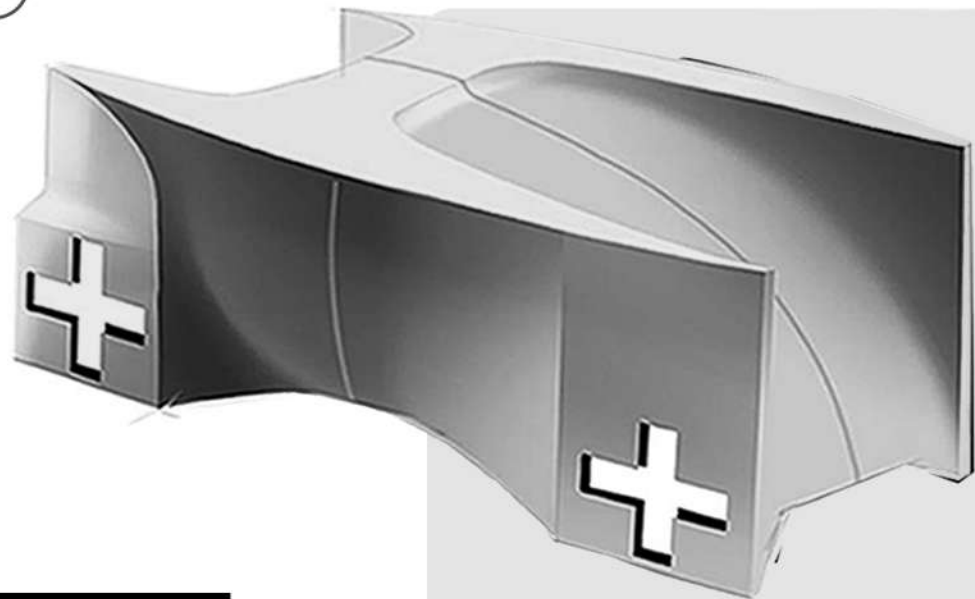
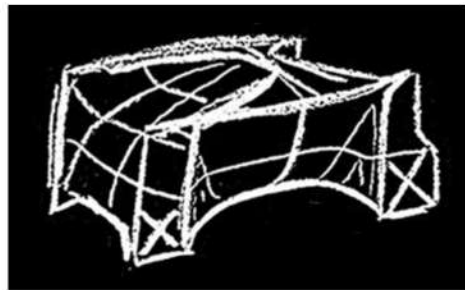

The boxy-shaped design, which prioritizes space efficiency, reflects a vision of future-oriented mobility with its rugged and functional form.



## Monolithic

Sharp lines and structured volumes echo the geometry of urban architecture, creating a natural connection with the city.

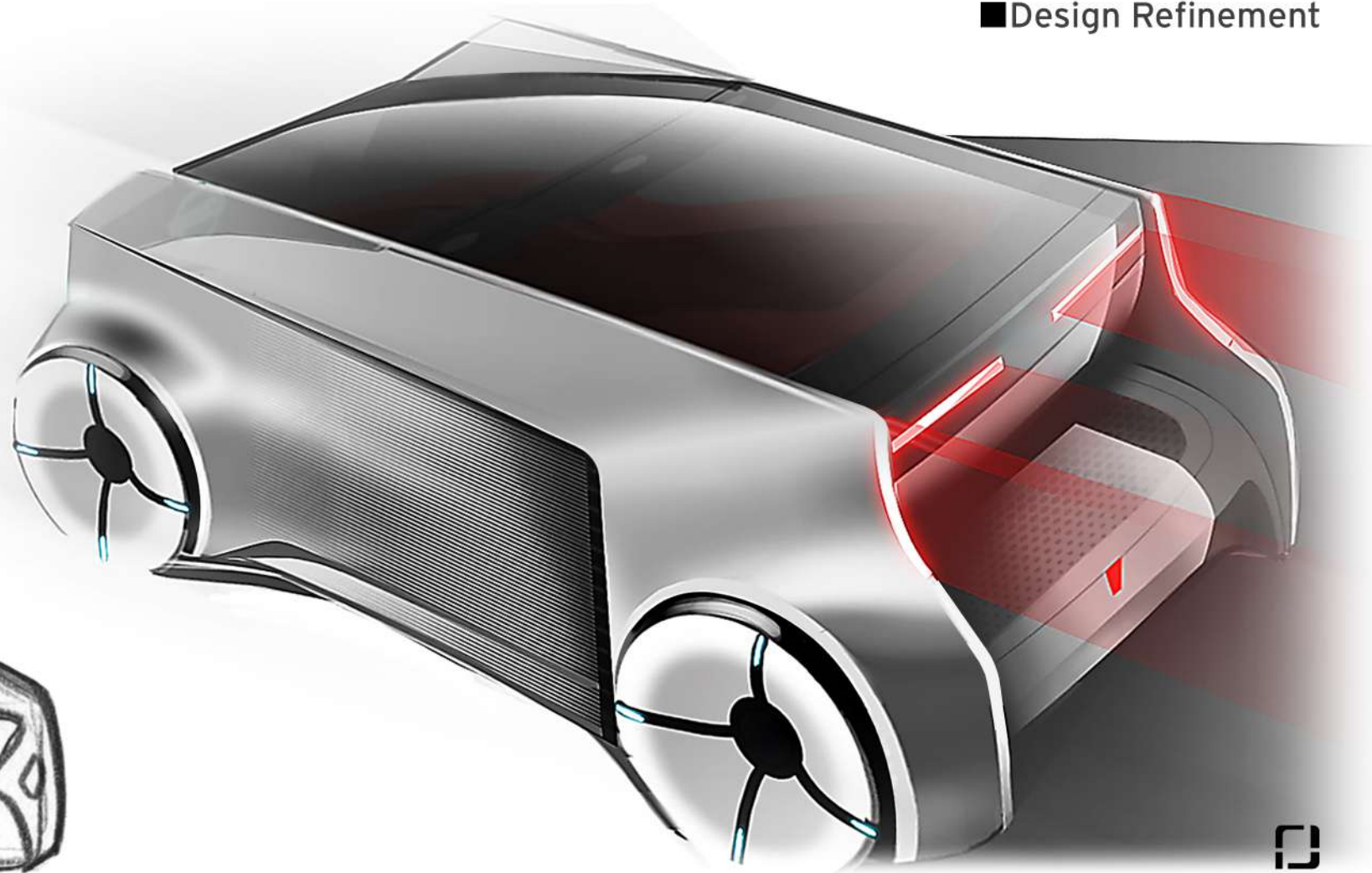
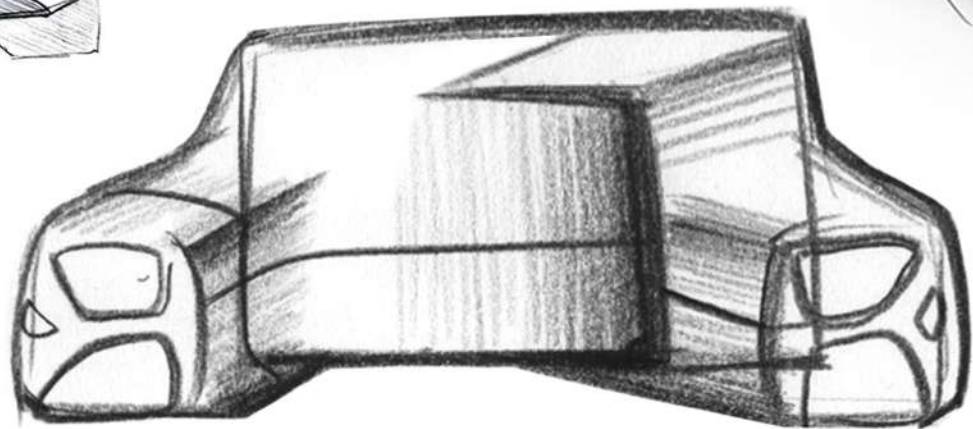
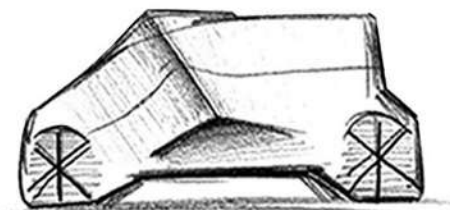
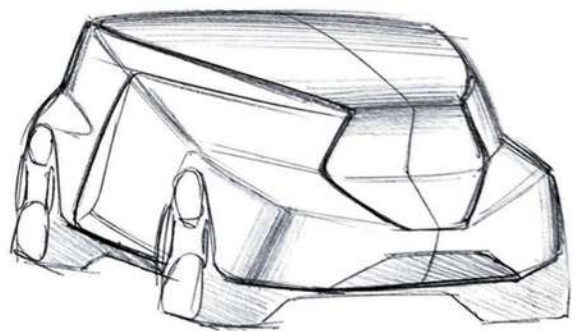
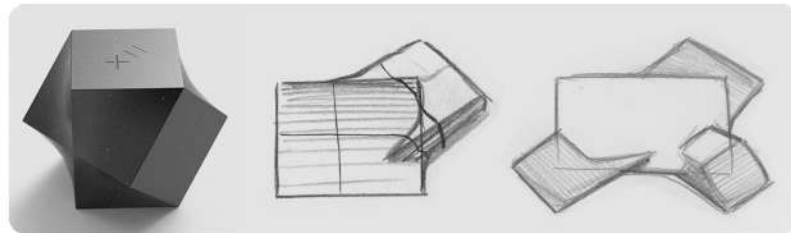

## Final EXT Design

2040 Nissan Zen Dimensions

OAL - 4195mm

OAW - 1800mm

OAH - 1670mm

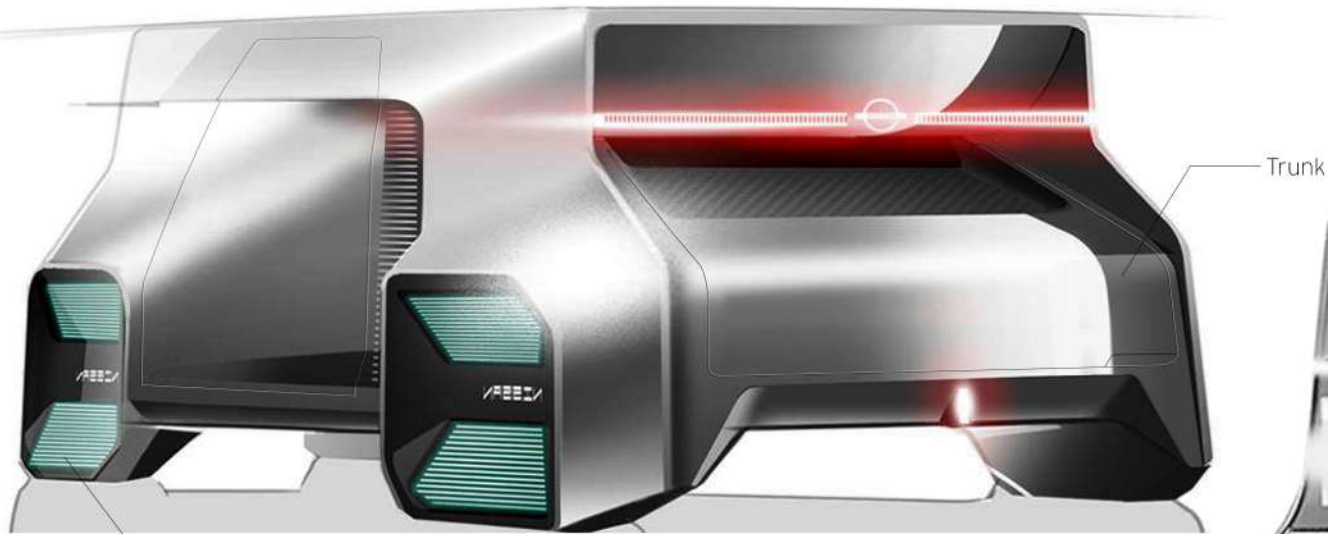

Automatic Sliding-door

Maglev Wheel

Air Purifier for Passenger



# Zen-Mobility

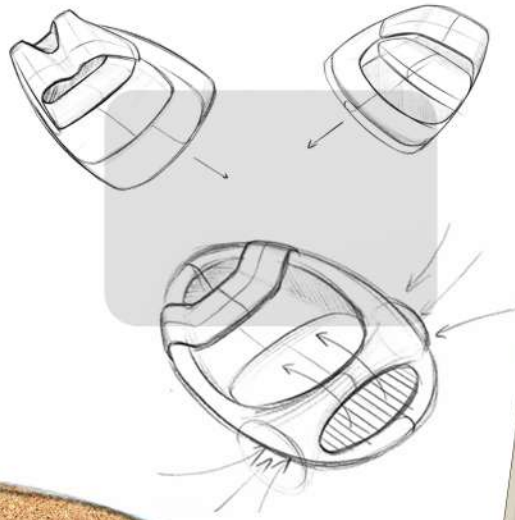

Wrap-around structure



Cork

## Interior Design

The wrap-around interior design, flowing from the dashboard to the door trim, presents a simple and unified aesthetic while providing the user with a sense of stability.



Floating type wide screen

Speaker

NISSAN

Controller

Phone charger & Arm rest

Dashboard made by 'recycled cork'



## Zen-Mobility

The ergonomic stretchable seat, air purifier system, and warm-colored interior provide passengers with a comfortable place to rest

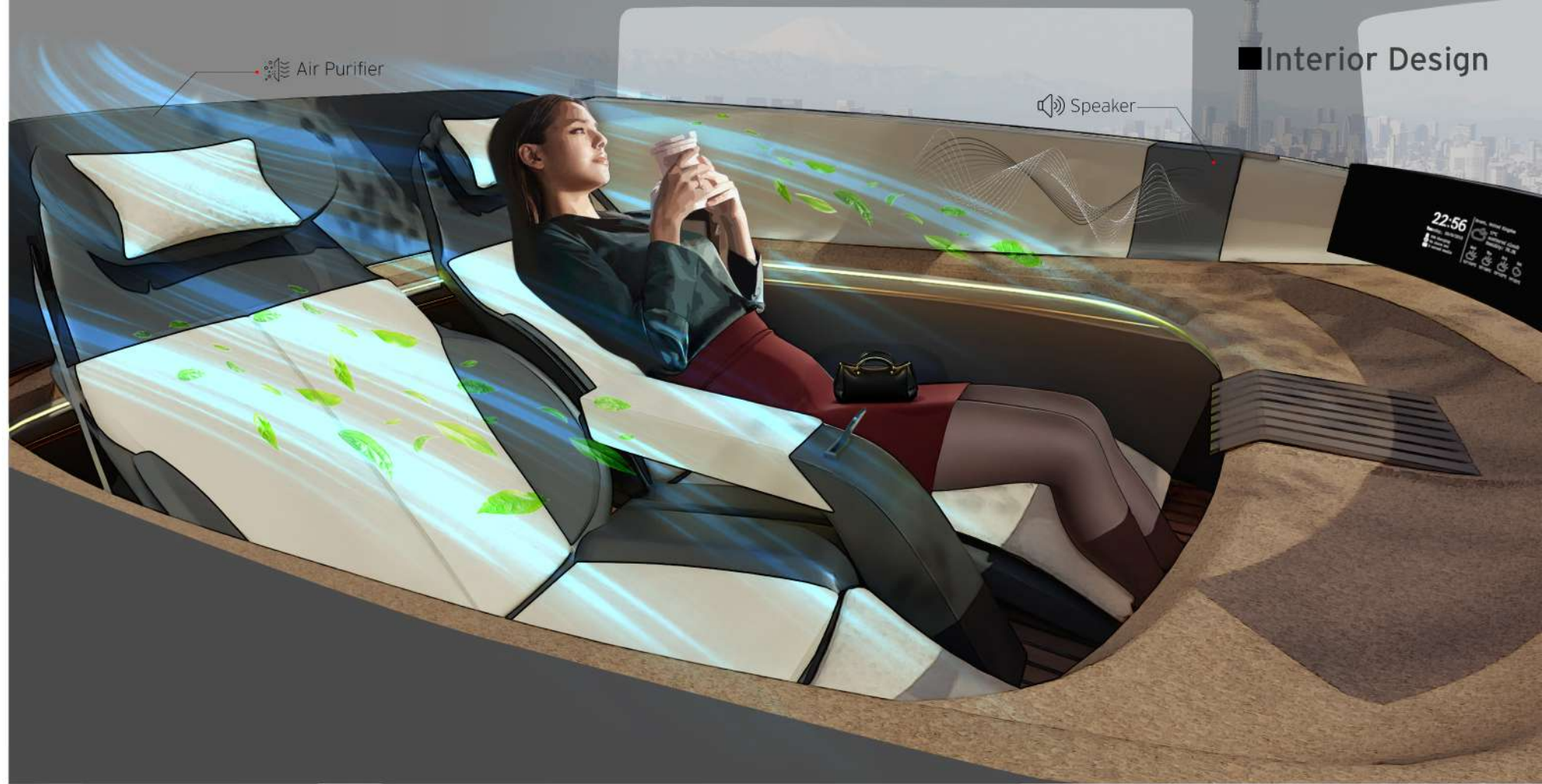



DAEIA | Baobab

American Chemistry Council sponsored Clay Model Project



### Streamline

The streamlined form enhances aerodynamic efficiency while creating a visually fluid and elegant presence in the urban environment.

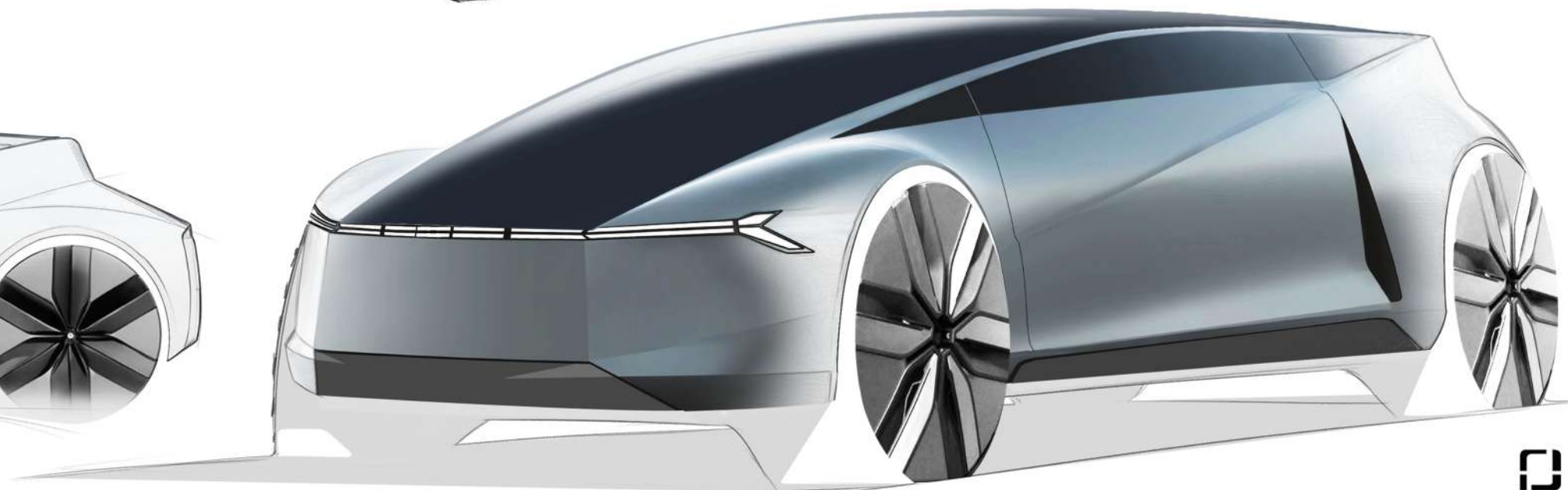
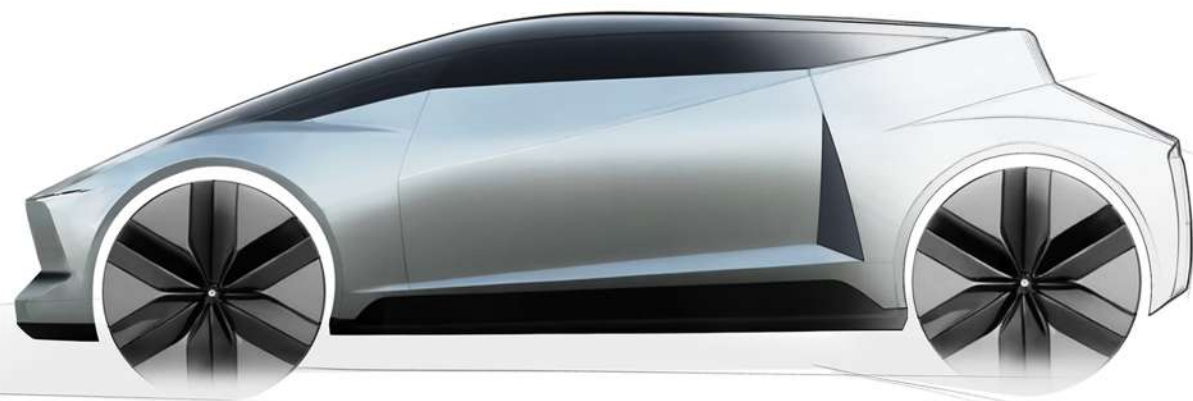
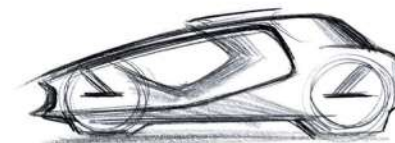
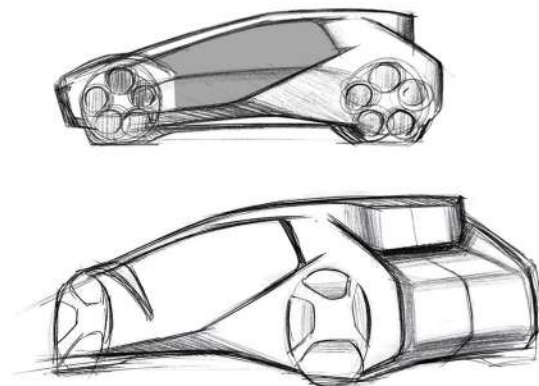
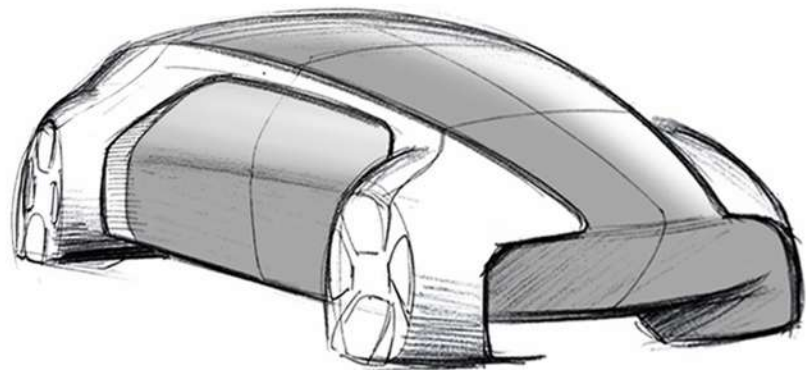



## Baobab

The cap-forward cabin line provides customers with maximum indoor space and shows a sleek and sexy side silhouette.



### ■ 3. Design Development

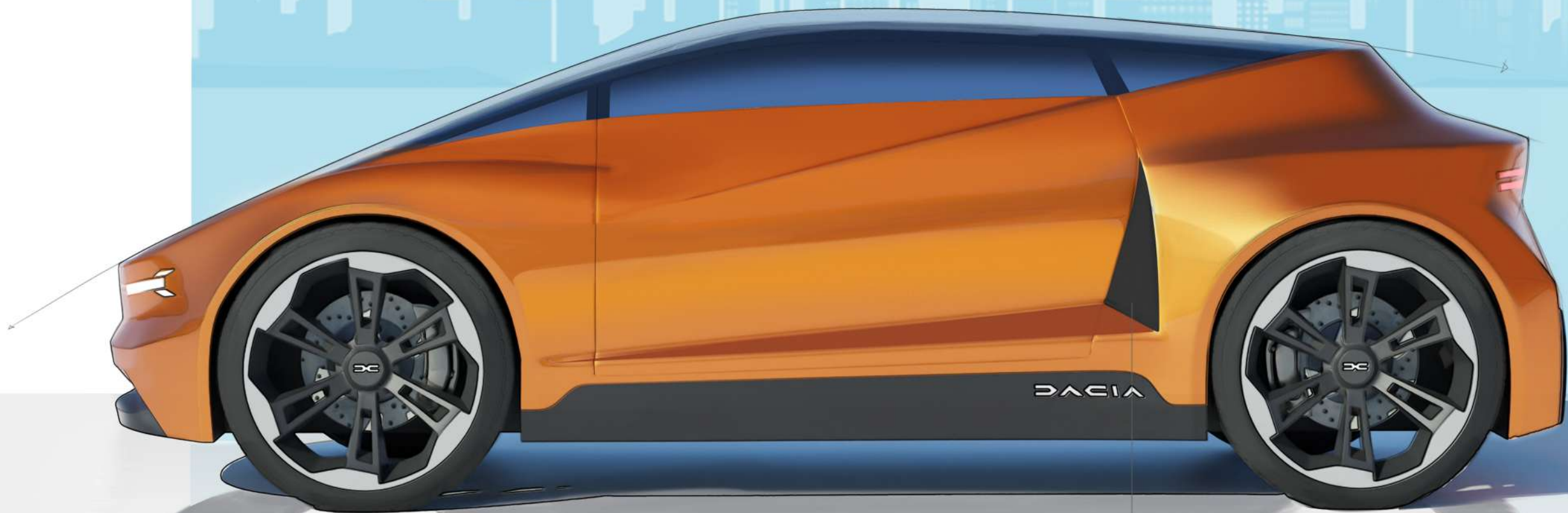

Air Purifier Filter



# Streamline

The cap-forward cabin line maximizes interior space for passengers and improves aerodynamic performance.

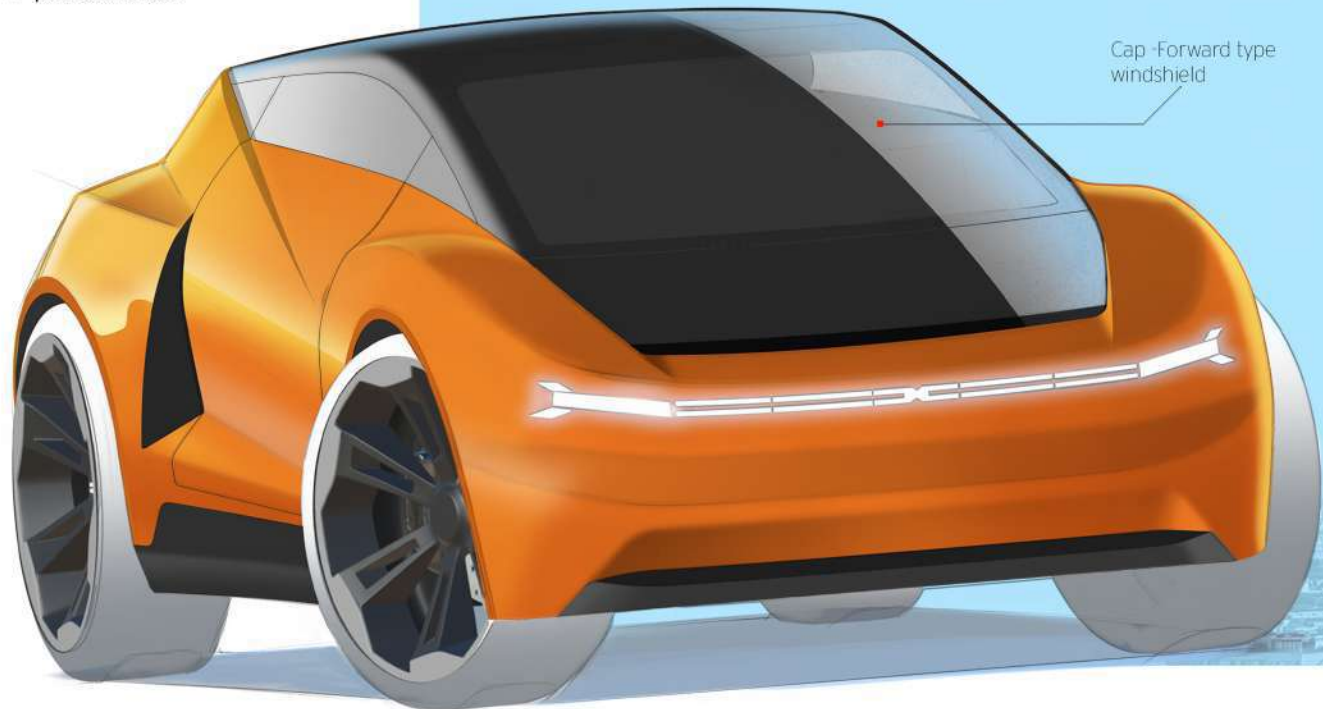

Cap-Forward type windshield

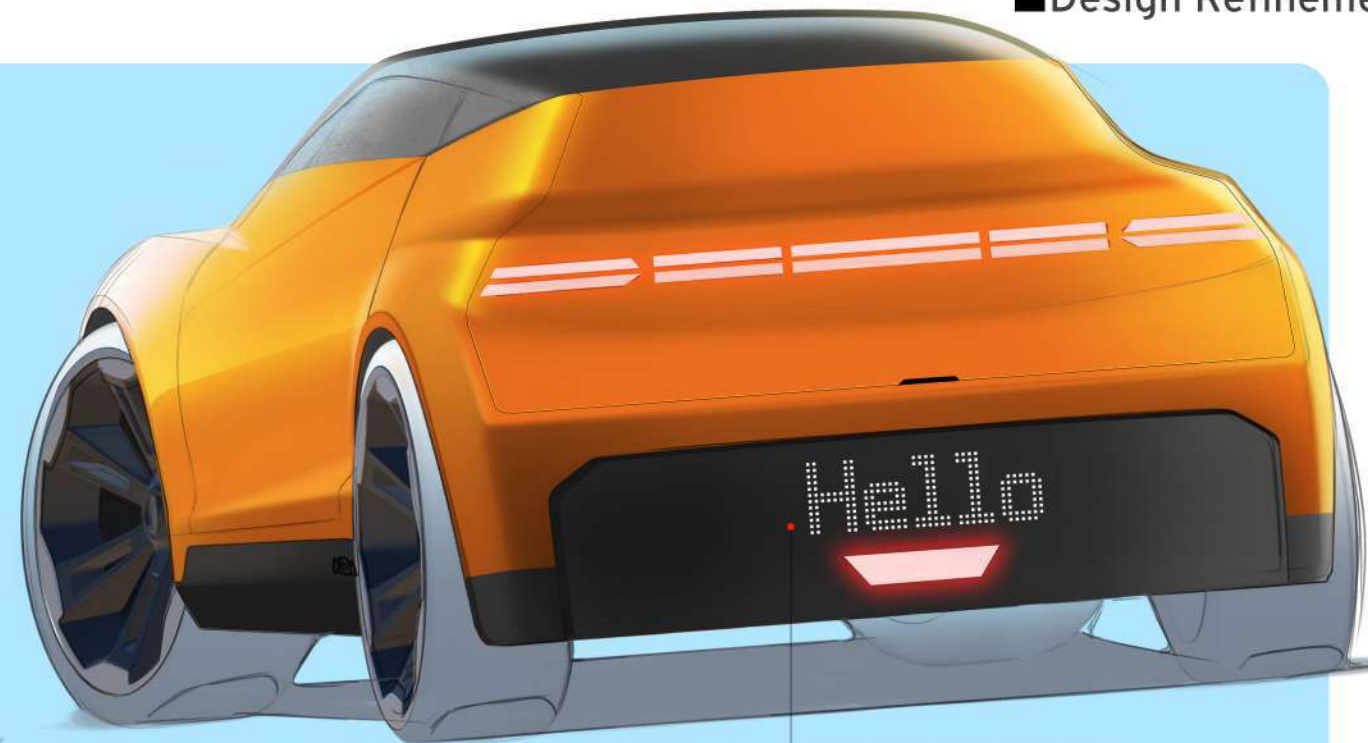

Rear information display & Rear autonomous driving sensor





# Baobab

Dimension  
Length : 4,251 mm  
Width : 1,850 mm  
Height : 1,399 mm  
Wheelbase : 2,751 mm  
Autonomous Level : 5

## 4. Vehicle Packaging

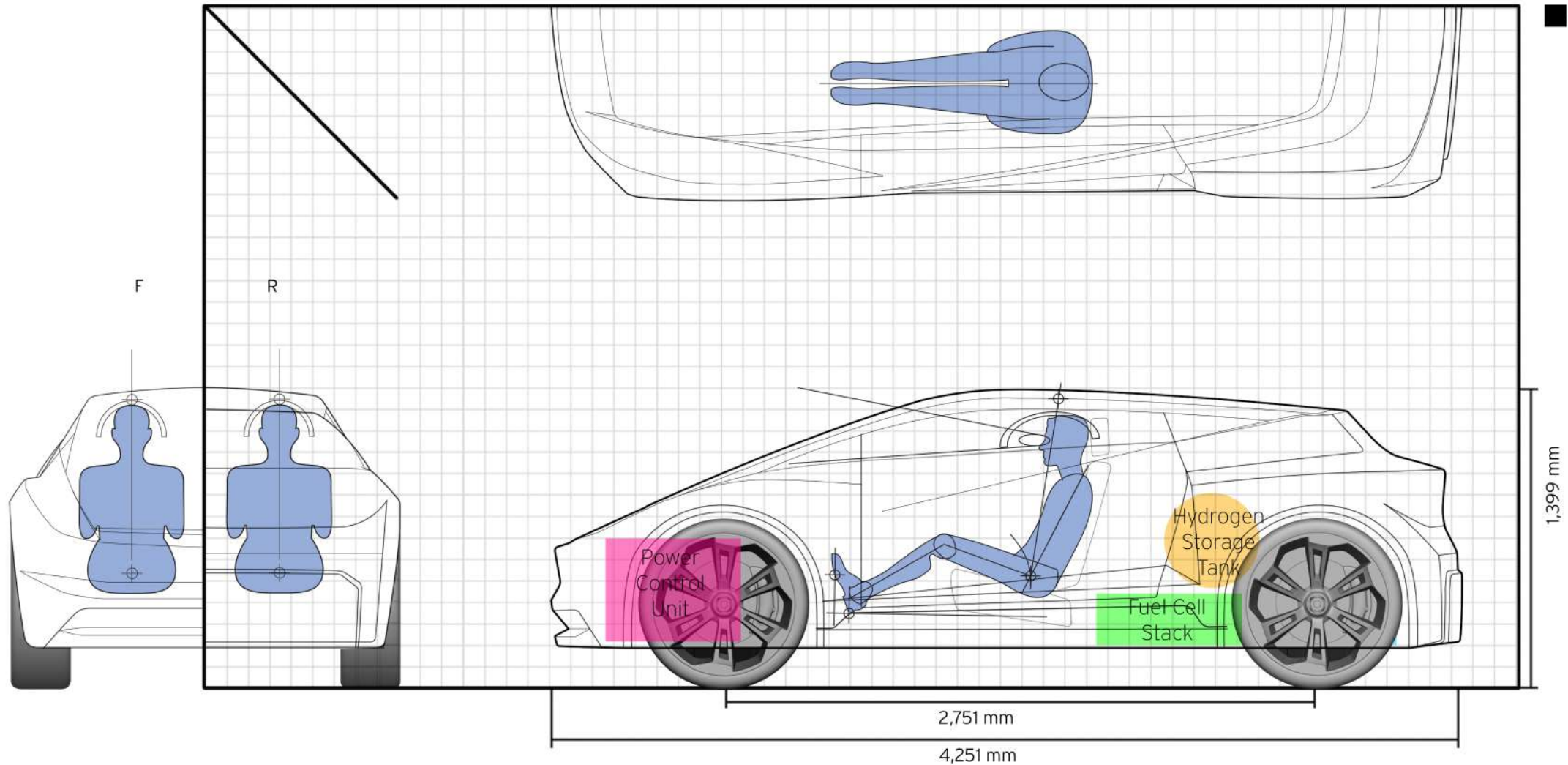

## Baobab

The cap-forward style sleek front design highlights the streamline and wide windshield maximizes the passenger's front view.



Autonomous Driving Front Sensor  
& Aero Dynamic Cap-forward Windshield

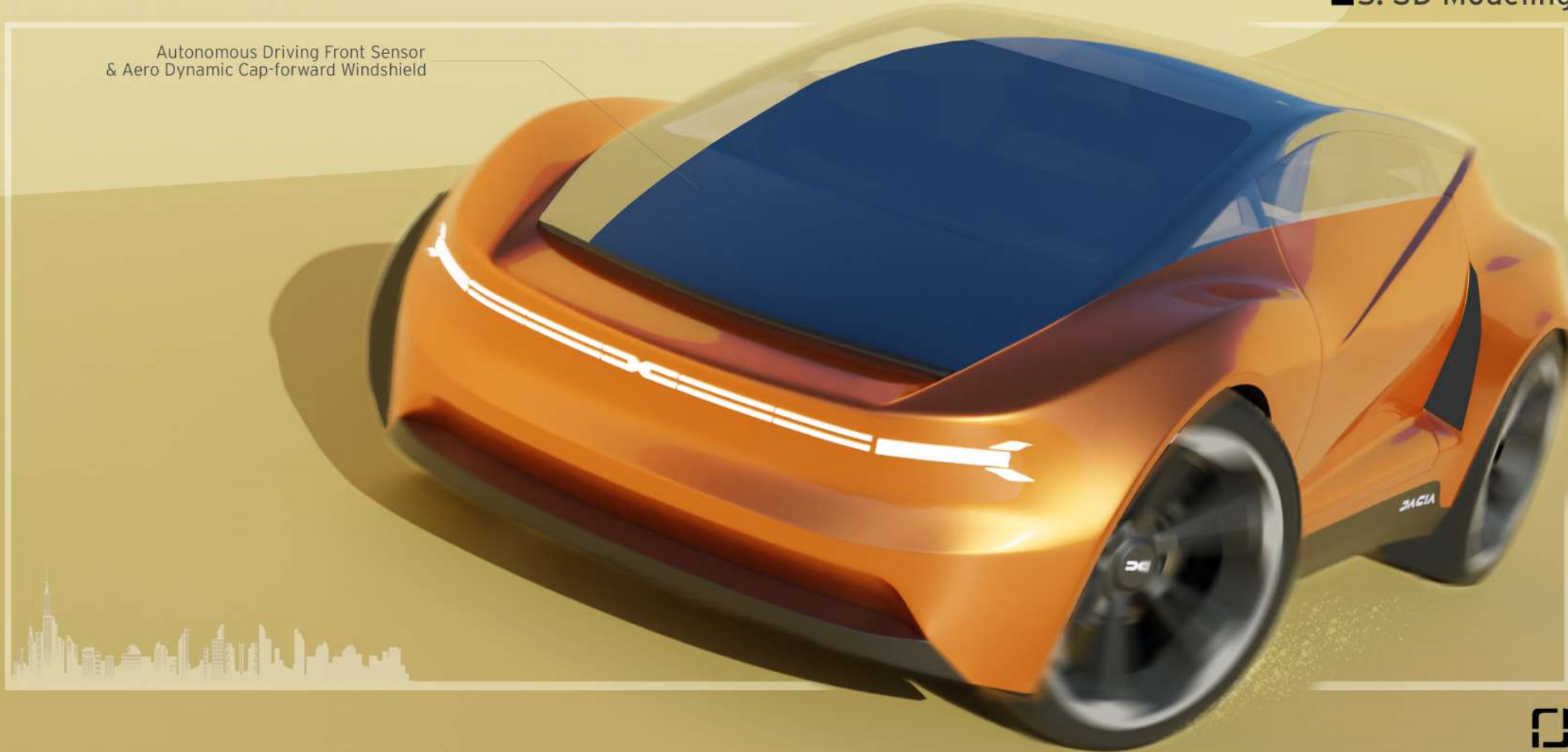

## Hydrogenic

The dynamic side character line, which descends from the rear roof toward the front, embodies Dacia's distinctive design language.



Rear information display &  
Rear autonomous driving sensor Panel

Autonomous Driving Side Sensor



## Baobab

This is a 1/5 scale hand-made clay model Project for 4 weeks during the semester. The beautiful reflection on the A Pillar and the sexy orange body color with pearls highlight this model even more.

### 1. Clay packing and Sculpting



### 2. Refining Process



### 3. Masking and Painting



### 4. Clear Coating and Finishing



DC  
DACIA

! Baobab





BENTLEY

# Aurora

2045 The new 'Clean-Luxury' Electric Boat Project





# Aurora



Name: Richard M.

Age: 46

Occupation: High-end Restaurant Owner

Location: London, UK

Lifestyle: Sophisticated, busy, success-driven, enjoys exclusive experiences

Needs : He is looking for a luxury boat that reflects his success and refined taste. He desires a private space where he can escape his busy daily life and unwind. He values premium materials, and a sensory experience that connects harmoniously with nature.



■ Target Customer





# Aurora

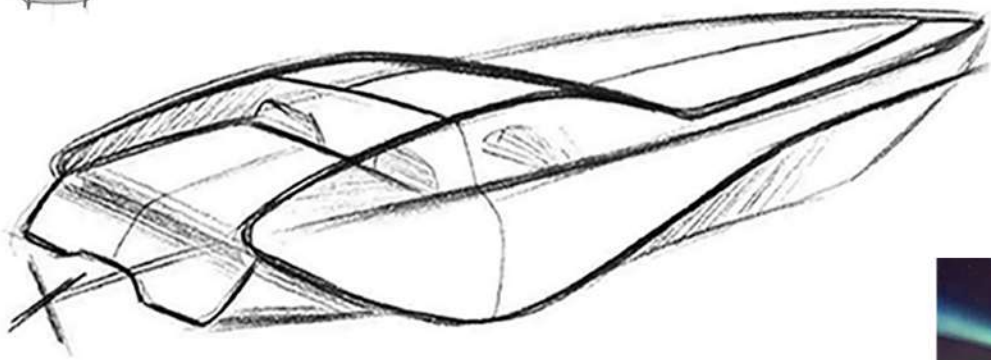
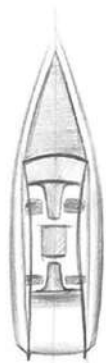

## Ext Ideations

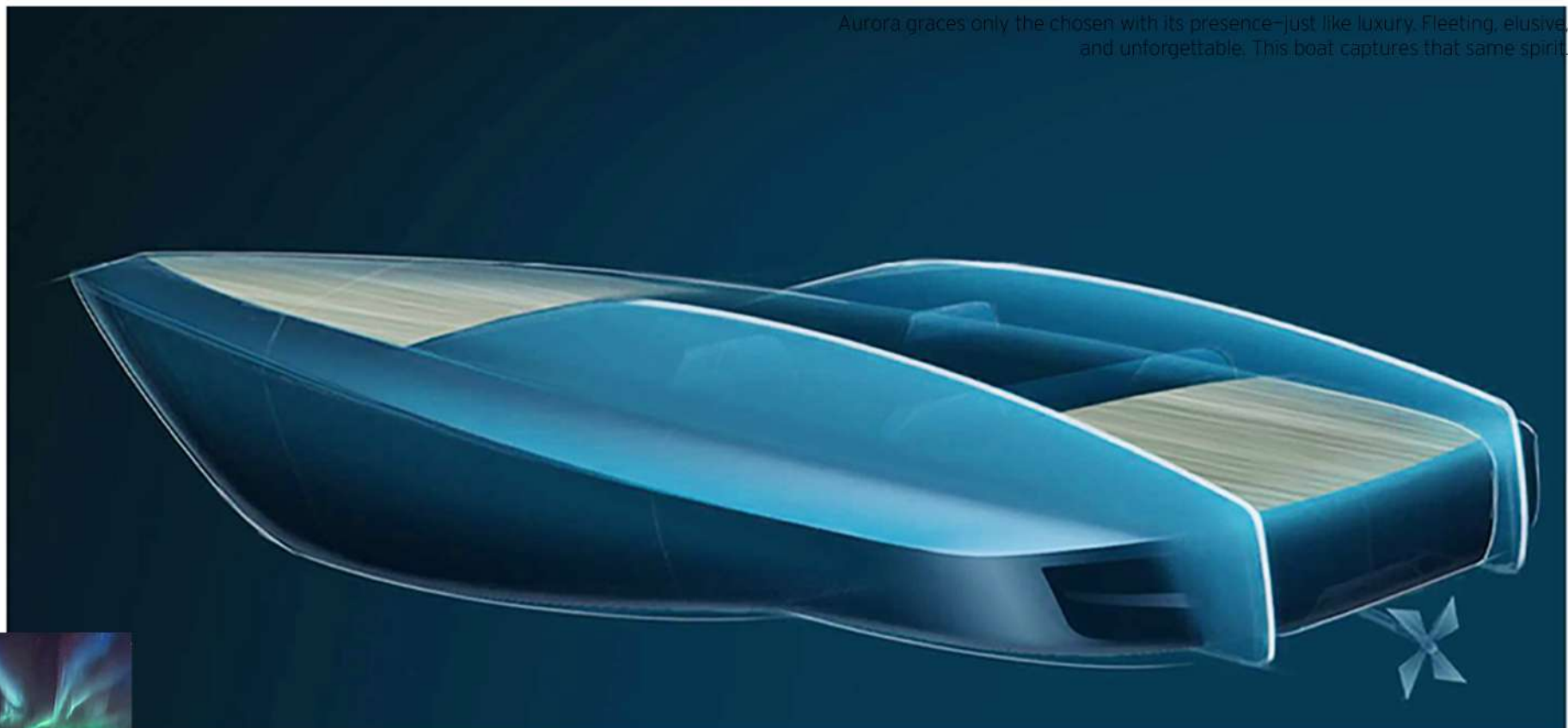

Aurora graces only the chosen with its presence—just like luxury. Fleeting, elusive, and unforgettable. This boat captures that same spirit.





# Aurora

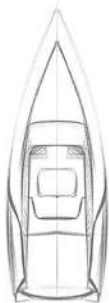
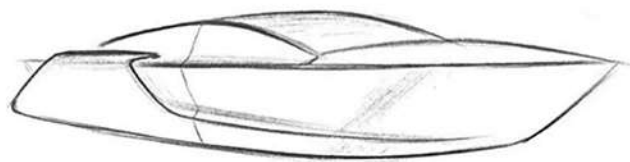
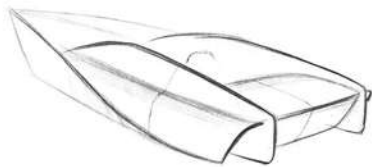

## Ext Ideations

Just as the Aurora appears only under the perfect conditions, this boat offers a rare and refined luxury, available only to the few who seek something extraordinary.





# Aurora

## Key Sketches

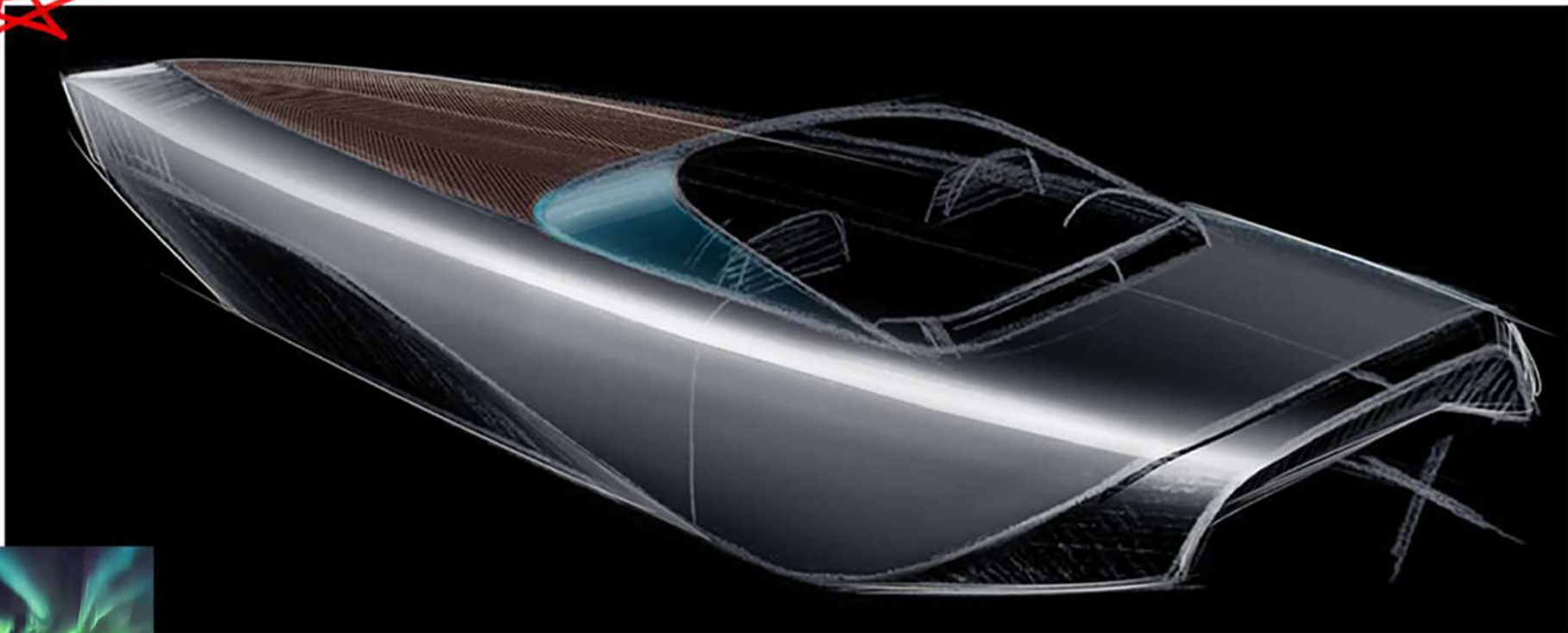
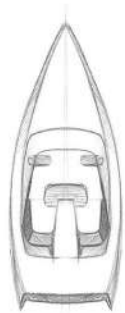
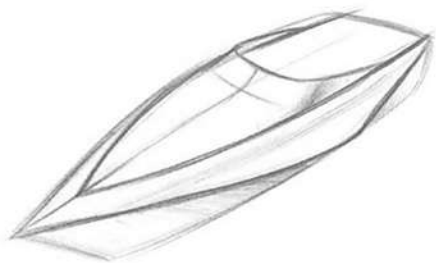

As the Aurora dances across the sky, the boat glides across the water—both timeless, both unforgettable.





# Aurora

Interior Design inspired by the form of several lines leading into one shape.

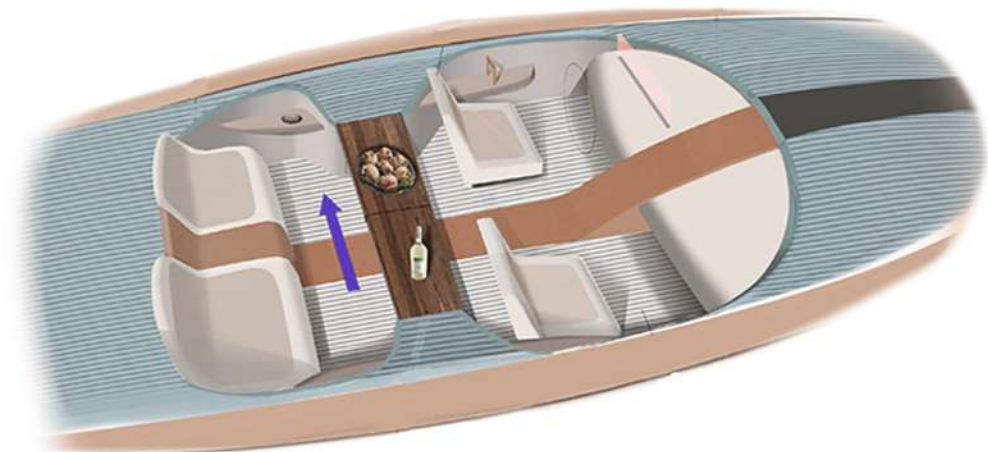
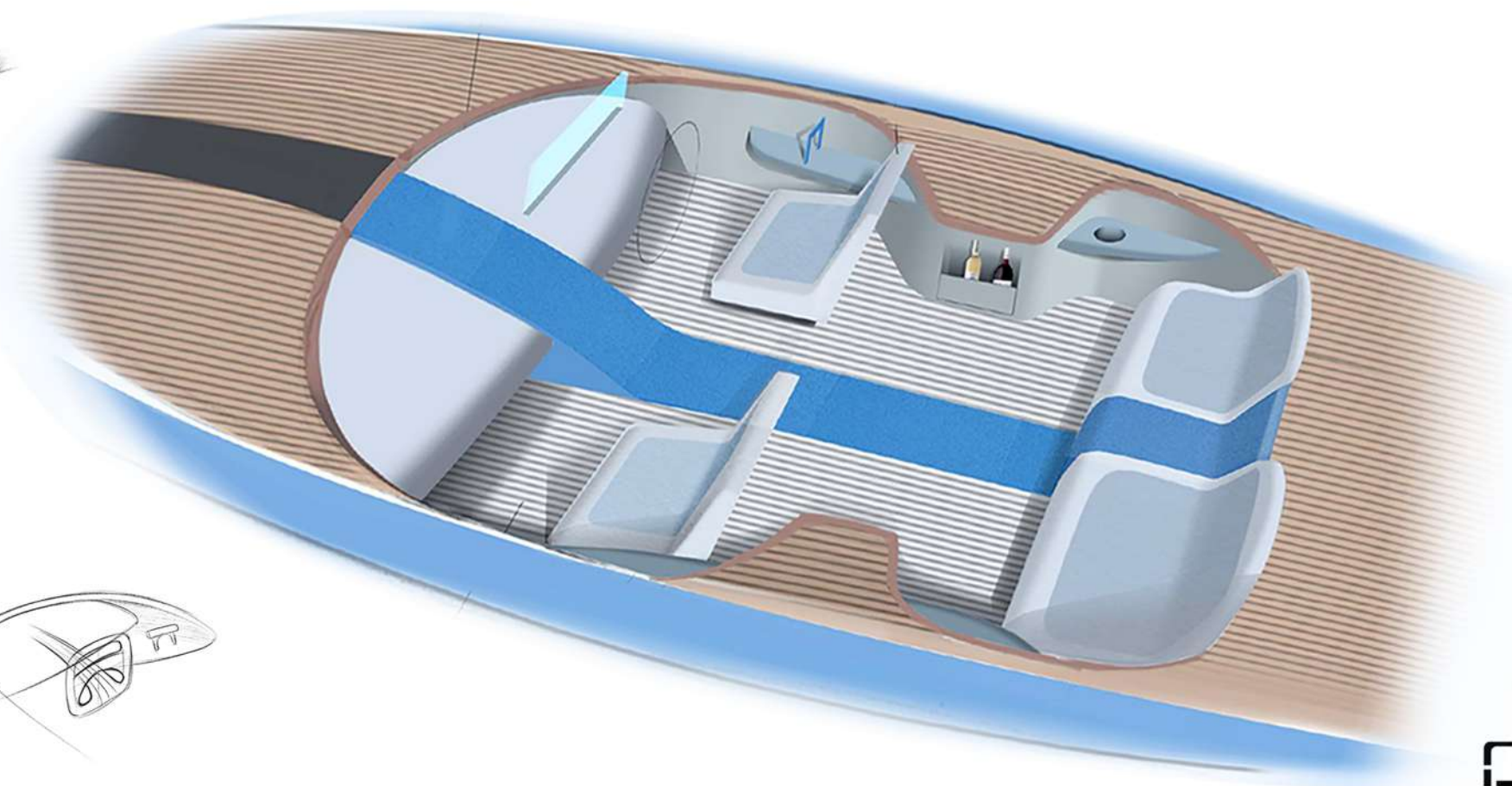
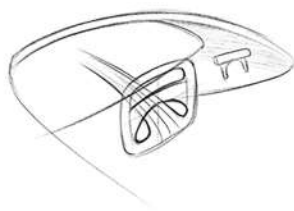
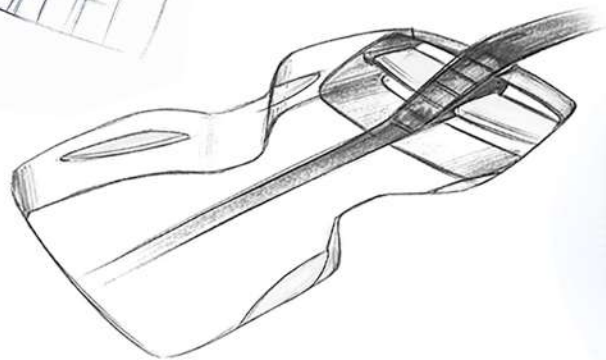
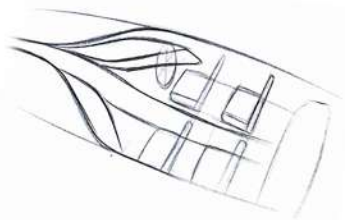



## Aurora

Inspired by the Aurora, the soft and fluid line from the stern flows seamlessly into the windshield, forming a single continuous gesture.



■ Ext Development





# Aurora

LOA : 28 FT  
BEAM : 9.5 FT  
HEIGHT : 6 FT  
DRAFT : 2.25 FT (27 IN)  
ENGINE : ELECTRIC MOTOR  
SHAFT TYPE : V-SHAFT  
HELL : DEEP V / FIGERGLASS  
GUESTS : 6

## Dimension

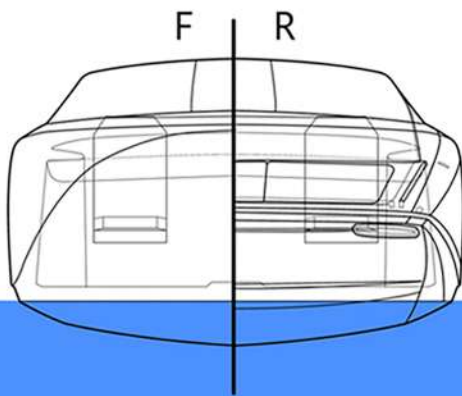
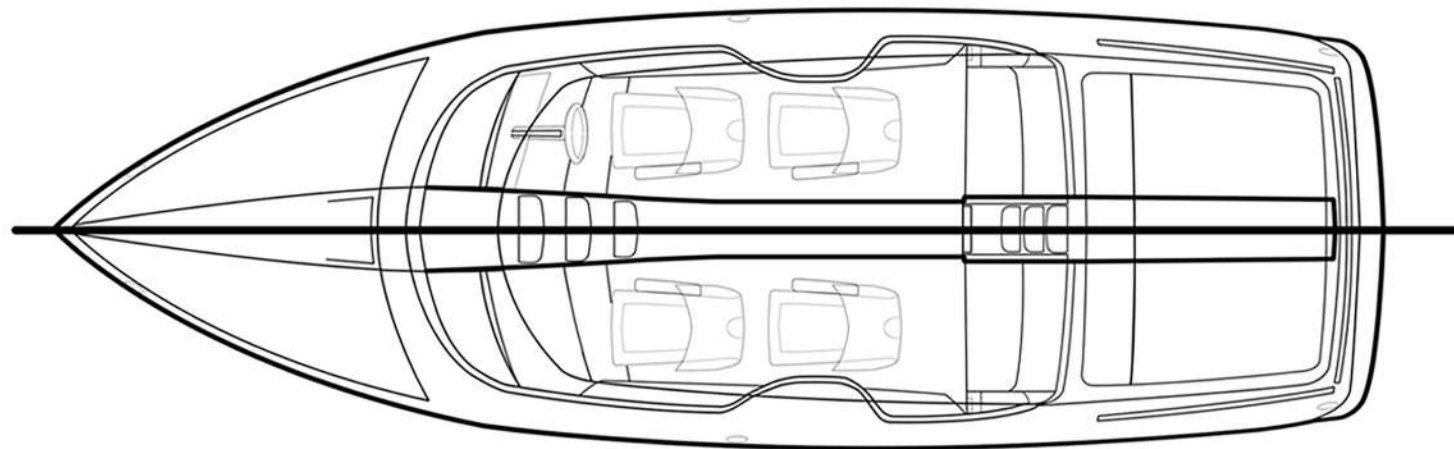

waterline

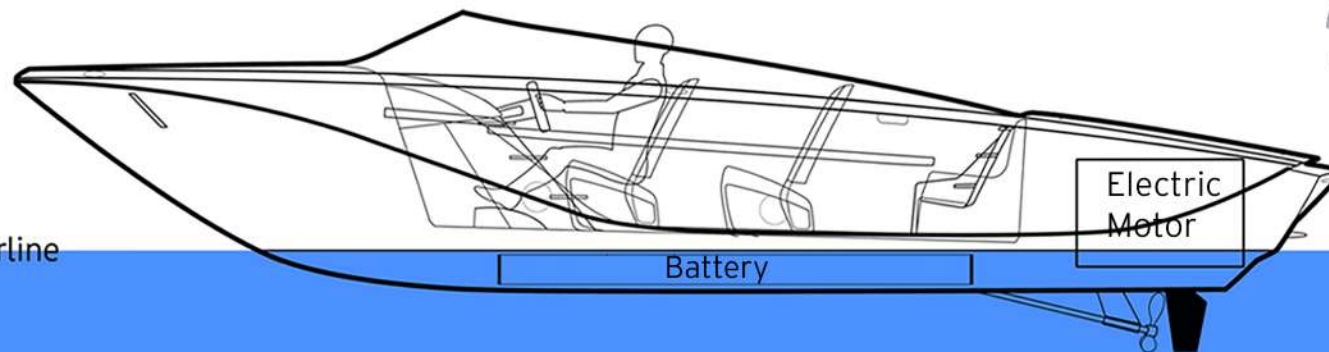

Evoy 300+Hp Electric Motor  
x2 (Total 600Hp)

Electric  
Motor

Battery

waterline





# Aurora

Crafted with next-generation materials, this 2040 luxury boat offers a refined tactile experience that redefines how luxury is felt.



## Material Details





## Aurora

Inspired by the Aurora, the soft and fluid line from the stern flows seamlessly into the windshield, forming a single continuous gesture.

Final Ext Design





## Aurora

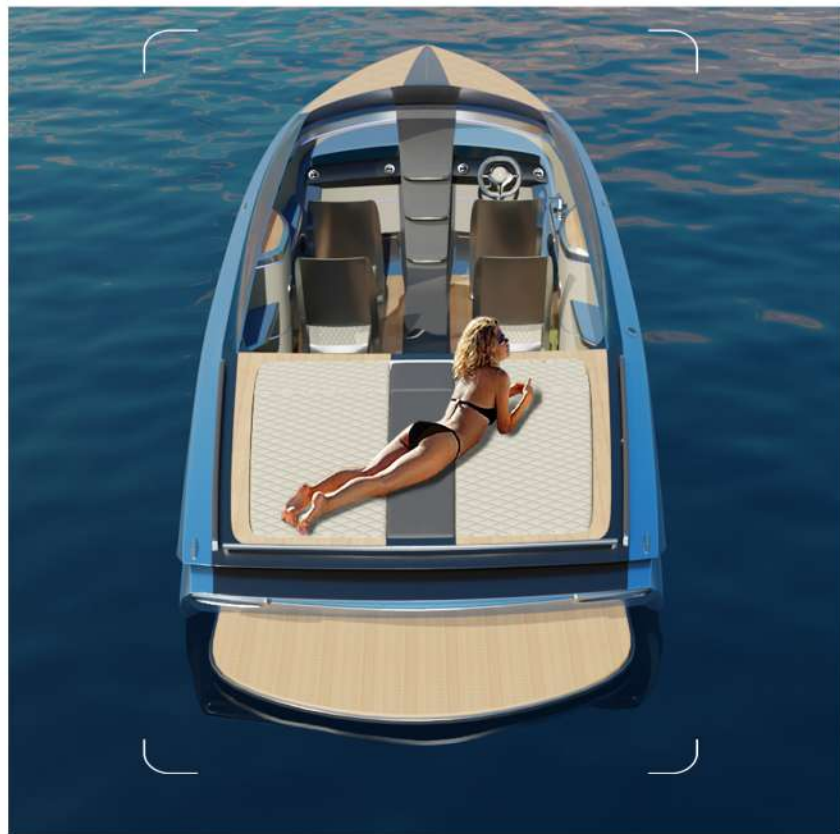

## Final Ext Design

The central line that runs from front to rear unifies the exterior and interior, creating a cohesive and harmonious design.





## Aurora

The layered lines of the Aurora are also applied to the rear of the hull, creating a distinctive design that sets this boat apart from conventional models.





# Aurora

Inspired by Bentley's GT model, the interior evokes the brand's signature luxury and high performance—reminding us that this is more than just a boat.



Steering Wheel inspired by Aurora

Foldable Sunbed



Slide-type Wine bar



## Int Ideations





| Aurora



Thank you so Much

